

戦略的国際共同研究プログラム(SICORP) 日本－中国共同研究  
終了報告書 概要

1. 研究課題名：「マイルド熱分解とエクセルギー再生に基づく低品位炭有効利用プロセスの開発」
2. 研究期間：2013年 4月～2016年 3月
3. 主な参加研究者名：  
日本側チーム

	氏名	役職	所属	研究分担
研究代表者	堤敦司	特任教授	東京大学 生産技術研究所	エクセルギー再生に 基づく高効率石炭 転換システム設計
主たる 共同研究者	伏見千尋	准教授	東京農工大学 大学院工学研究院 応用化学部門	マイルド水蒸気熱 分解による低品位 炭からの油分生成
主たる 共同研究者	鈴木善三	上級主任 研究員	産業技術総合研究所 創エネルギー研究部 門	低品位炭の流動層 ガス化
主たる 共同研究者	松岡浩一	グループ長	産業技術総合研究所 創エネルギー研究部 門	低品位炭の流動層 ガス化
主たる 共同研究者	宝田恭之	教授	群馬大学 大学院理工学研究院	触媒を用いた低炭 化度炭の低温熱分 解/ガス化
主たる 共同研究者	官国清	教授	弘前大学 北日本新エネルギー 研究所	低品質石炭/バイ オマスの高効率な 共熱分解・共ガス 化・共水素化熱分 解技術の開発
主たる 共同研究者	鷹觜利公	グループ長	独立行政法人 産業 技術総合研究所・エ ネルギー技術研究部 門 新燃料グループ	低品位炭の水熱抽 出・改質技術の開 発
主たる 共同研究者	則永行庸	准教授	九州大学 先導物質化学研究所	石炭マイルド熱分 解油の熱的および 水素化分解反応の 速度モデリング
主たる 共同研究者	米山嘉治	准教授	富山大学大学院 理工学研究部(工学)	触媒反応プロセス による石炭由来油 の水素化改質
研究期間中の全参加研究者数			9名	

## 相手側チーム

	氏名	役職	所属	研究分担
研究代表者	Wei Huang	Director, Professor	Taiyuan University of Technology, Key Laboratory of Coal Science and Technology	Exergy Recuperative Coal Pyrolysis and Gasification
主たる共同研究者	Xiaogang Hao	Professor	Taiyuan University of Technology, Department of Chemical Engineering	Exergy Recuperative Coal Pyrolysis and Gasification
主たる共同研究者	Shiqiu Gao	Professor	Institute of Process Engineering, Chinese Academy of Sciences	Total System Design, Exergy Analysis and Pilot Experiment
主たる共同研究者	Haoquan Hu	Professor	Dalian University of Technology	Exergy Recuperative Coal Pyrolysis and Gasification
主たる共同研究者	Xiaoxun Ma	Professor	Northwest University, School of Chemical Engineering	Coal-derived liquid refinery
主たる共同研究者	Xianyong Wei	Professor	China University of Mining & Technology, School of Chemical Engineering	Coal-derived liquid refinery
主たる共同研究者	Songjiang Ma	Professor	Hunan University of Science and Technology	Exergy Recuperative Coal Pyrolysis and Gasification
研究期間中の全参加研究者数			7名	

## 4. 共同研究の概要

本研究開発では、将来の日中両国のエネルギー確保の観点から重要な中国の低品位炭（褐炭、亜瀝青炭）および高水分・難粉碎性の燃料に対応可能な、熱分解・ガス化・タールの分離・反応によって高付加価値化学品・高品質燃料を高効率で製造するプロセスの開発を目的とした。

日中両国の研究者が協力することで、研究期間内で下記の目標を達成した：

- (1) 中国の低品位炭の特性とマイルド熱分解・ガス化の関係を解明。
- (2) 中国の低品位炭（褐炭、亜瀝青炭）、高水分・難粉碎性の燃料にも対応可能で、熱分解・ガス化・タールの分離・反応によって高付加価値化学品・高品質燃料を高効率で製造する技術を開発。
- (3) エクセルギー再生理論および自己熱再生技術に基づく熱分解とガス化を組み合わせた革新的プロセスの設計を行うとともに、パイロット実証実験を実施し、プロセスの技術基盤を構築。

## 5. 共同研究の成果

## 5-1 共同研究の学術成果

石炭の熱分解、ガス化および石炭由来油の改質の分野における日本・中国両国の研究者が協力することで、プロセス全体のエクセルギー損失を最小とするとともに二酸化炭素の排出を低減させることができる、低品位炭から高品位液体燃料（HQO）、合成ガスおよび高

付加価値化学品 (Value-Added Chemicals, VACs) のコプロダクションプロセスを開発した。

出来る限り多くの石炭由来油を得るために、まず低温 (450-600°C) または中温 (700-850°C) のマイルドな条件下で石炭を熱分解し、得られた液状成分 (タール) は接触分解反応分離および水素化転化により、高品質燃料油、高付加価値化学品および炭素材料を製造するプロセスの検討を実施した。このとき必要な水素はマイルド熱分解によって得られたメタン-リッチガスを水蒸気改質して得ることができた。一方、マイルド熱分解によって生成したチャーは低温でエクセルギー再生水蒸気改質ガス化あるいは部分酸化ガス化し合成ガス (CO、H<sub>2</sub>) に転換した。さらに、プロセス全体および各単位操作は、エクセルギー再生理論および自己熱再生技術を適用し、エクセルギー損失を最小化および二酸化炭素の排出の低減を図ったプロセスの最適設計を行うとともに、熱分解とガス化を組み合わせたプロセスの検討を行い、グリーンな低品位炭からの高品位液体燃料、高付加価値化学品、炭素材料、水素および電力のコプロダクションシステムを提案した。

## 5-2 国際連携による相乗効果

本プロジェクトでは三つのタスクを設けた：

(1) プロセス設計とエクセルギー解析；(2) マイルド熱分解とガス化；(3) 石炭由来油リファイナリー

タスク (1) では、日本側は、エクセルギー再生を基に石炭の高効率変換プロセスの全体システム設計を行った。一方、中国側は、エクセルギー解析とプロセス設計に基づいて、廃スチームを再生させて利用する石炭の熱分解とチャーのガス化を組み合わせたパイロット試験を実施した。

タスク (2) は、マイルド熱分解およびエクセルギー再生ガス化の基礎的研究を行った。中国側を中心に、マイルド熱分解における解重合の反応機構を明らかにした。ラボスケールの循環流動層ガス化装置を用いて連続熱分解・ガス化を行い、中国側でも、粉粒流動層熱分解炉とガス化炉を組み合わせた熱分解・ガス化装置により実験を行った。得られた実験結果は、中国側が実施するパイロット試験での参考データとして活用された。日本側の研究者が、低品位炭水蒸気ガス化試験を行い、多くの燃料油を得る最適条件 (反応温度およびスチーム濃度) を探索した。また、石炭とバイオマスのコプロセッシングで、マイルドな条件下での低品位炭とバイオマスの共熱分解および共水素化分解を試みた。低温熱分解/ガス化用の触媒開発を行うとともに、開発した触媒を用いて、小型流動層反応器による熱分解/ガス化試験を行った。

タスク (3) は、熱分解/ガス化で得られたタール成分をアップグレーディングする石炭由来油のリファイナリー体系の構築を行った。石炭由来油の水素化改質用の触媒の開発を行い、水素化改質反応の最適条件を調べた。クラッキングや水素化分解反応に関する速度モデリングを実施し、原料油の組成や反応条件を与えることで、反応後の改質油の沸点分布などの主要特性を予測できる反応モデルを構築し、さらに、より多くの石炭由来油を生産する手法として新規水熱抽出 (Hydrothermal extraction) 法を開発した。中国側では、メタンリッチガスの改質と石炭の熱分解を組み合わせて、より多くの石炭由来油を生産しようとする方法、熱分解で得られたタール成分から VHCs、PAPs、ONs、アスファルトを抽出分離し、さらに水素化転化する方法を検討した。

## 5-3 共同研究成果から期待される波及効果

本研究の目的である、石炭の熱分解、ガス化および石炭由来油の改質の分野における日本・中国両国の研究者が協力し、プロセス全体のエクセルギー損失を最小とするとともに二酸化炭素の排出を低減させることができる、低品位炭から高品位液体燃料 (HQO)、合成ガスおよび高付加価値化学品 (Value-Added Chemicals, VACs) のコプロダクションプロセスの開発を行ったことで多くの知見を得た。これらの成果を発展させることで、石炭資源の有効な利用によって急速な石炭資源減少の防止と単位石炭量当りより多くのエネルギーを生産し日中両国の共通の課題となっている CO<sub>2</sub> 排出量を低減していくことができる。褐

炭や亜瀝青炭などの低品位炭は世界の石炭資源の 50%、中国の石炭資源の 60%にもなり、それらは間違いなく将来の石炭エネルギー資源の主流になると思われるが、これらも有効に利用することができる。

Strategic International Collaborative Research Program (SICORP)  
Japan – China Joint Research Program  
Executive Summary of Final Report

1. Project Title : 「Technology development and process integration for efficient utilization of low-rank coals based on mild pyrolysis and exergy recuperation」
2. Project Period : April 1, 2013 ~ March 31, 2016
3. Main Participants :

Japan-side

	Name	Title	Affiliation	Role
PI	Atsushi Tsutsumi	Professor	The University of Tokyo Collaborative Research Center for Energy Engineering, Institute of Industrial Science	Task 1
Co-PI	Chihiro Fushimi	Associate Professor	Tokyo University of Agriculture and Technology, Department of Chemical Engineering	Task 2
Co-PI	Yoshizo Suzuki	Group leader	National Institute of Advanced Industrial Science and Technology, Clean Gas Research Group	Task 2
Co-PI	Koichi Matsuoka	Group leader	National Institute of Advanced Industrial Science and Technology, Clean Gas Research Group	Task 2
Co-PI	Takayuki Takarada	Professor	Gunma University, Department of Biological and Chemical Engineering	Task 2
Co-PI	Guoqing Guan	Professor	Hirosaki University, North Japan Research Institute for Sustainable Energy	Task 2
Co-PI	Toshimasa Takanohashi	Group leader	National Institute of Advanced Industrial Science and Technology, Advanced Fuel Group	Task 2
Co-PI	Koyo Norinaga	Associate Professor	Kyushu University, Institute for Materials Chemistry and Engineering	Task 3
Co-PI	Yoshiharu Yoneyama	Associate Professor	University of Toyama, Department of Applied Chemistry	Task 3
Total number of participating researchers in the project: 9				

Partner-side

	Name	Title	Affiliation	Role
PI	Wei Huang	Professor	Taiyuan University of Technology	Task 2

Co-PI	Shiqiu Gao	Professor	Institute Of Process Engineering, Chinese Academy Of Sciences	Task 1
Co-PI	Haoquan Hu	Professor	Dalian University of Technology	Task2
Co-PI	Xiaoxun Ma	Professor	Northwest University	Task2
Co-PI	Songjiang Ma	Professor	Hunan University of Science and Technology	Task2
Co-PI	Xianyong Wei	Professor	China University of Mining and Technology	Task3
Total number of participating researchers in the project: 6				

#### 4. Scope of the joint project

Three main research tasks was conducted: (1) process design and exergy analysis; (2) mild pyrolysis and gasification; and (3) coal-derived liquid refinery.

In the task (1), total system (or some unit operations with high energy consumption) design for highly efficient coal conversion based on exergy recuperation was conducted in Japan side, and based on the exergy analysis and process design, a pilot experiment for the coupling of pyrolysis of coals and char gasification by recuperation of exhausted steam were performed in China side. In Japan, applicants had developed an exergy recuperative coal gasification system for IGCC/IGFC. In this system, exhaust heat from SOFC/gas turbine was recuperated and utilized for heat of endothermic reaction

#### 5. Outcomes of the joint project

##### 5-1 Intellectual Merit

1. One apparatus coupling pyrolysis and gasification was established, as Fig.1, and the effects of operating condition was investigated for the production of CH<sub>4</sub>-rich syngas and tar;
2. A pilot-scale dual fluidized bed combined coal pyrolysis and char gasification, as Fig.2, was set up and operated for producing fuel gas or syngas;
3. An in-situ pyrolysis-time of flight mass spectrometry was constructed, as Fig.3, and it was used to investigate the pyrolysis behavior of coal model compounds and coal samples;
4. A non-thermal plasma reactor for the methane-rich gas reforming was designed and constructed, as Fig.4, and the effects of the parameters of power supply and the experiments on the reforming of CH<sub>4</sub>-rich gas were investigated;
5. The reaction parameters for integrated process of steam reforming of methane with coal pyrolysis were optimized in order to improve the tar yield and quality;
6. One powder-particle fluidized bed was established, as Fig.5. The experimental results by using this apparatus have a good repeatability;
7. The supported zeolite catalysts for Xinjiang coal pyrolysis have a certain role in pyrolytic products lightening and can increase the yields of BTX;
8. One method was adopted to analyze the components of low temperature coal tar by GC-MS and TG-FTIR
9. Low temperature coal tar fractions were separated step by step on the basis of selective reactions;
10. Setting up a 300 kg/h pilot-scale equipment for coal pretreatment for catalytic depolymerization and a Soxhlet extraction equipment with 300g raw coal per time, as Fig.6 and Fig.7;
11. An experimental equipment was developed for middle- and low-temperature coal tar separation, as Fig.8, its Batch-processing capacity is 5 kg;

12. The sulfur content in char was reduced obviously by catalytic depolymerization;
13. Finding the catalyst locating on the electro-negativity atoms form extracted residues catalytic depolymerization and char depolymerized again by catalysts;
14. One highly active Ni/ZSM-5 catalyst for arene hydrogenation was prepared, Over this catalyst, light portions from both high-temperature coal tar and light-temperature coal tar can be hydrogenated to colorless and transparent liquids;
15. One Mathematical model was put forward for predicting slurry-ability of semi-coke, as follows

$$\phi = 72.369 - 0.067[V_{ad}] - 1.217[M_{ad}] - 0.006[C/H] \quad R = 0.9057$$

$\phi$  refers to the maximum slurry concentration of semi-coke;

$V_{ad}$  refers to the volatile content in air dry basis;

$M_{ad}$  refers to the moisture content in air dry basis;

$C/H$  refers to the mass ratio of carbon to hydrogen.

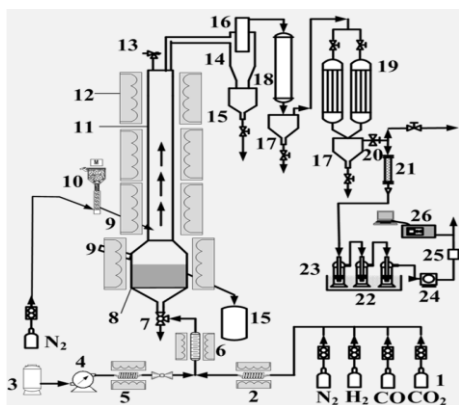

Fig.1 A bench scale integrated fluidized bed system



Fig.2 A pilot-scale dual fluidized bed

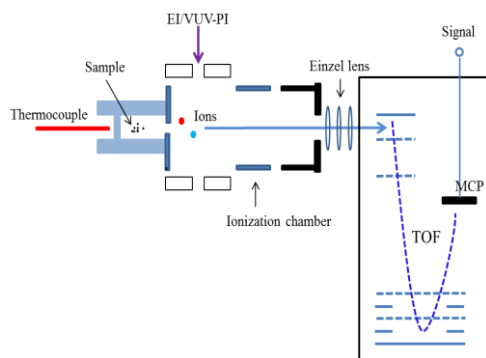

Fig.3 Schematic diagram of PY-TOF-MS

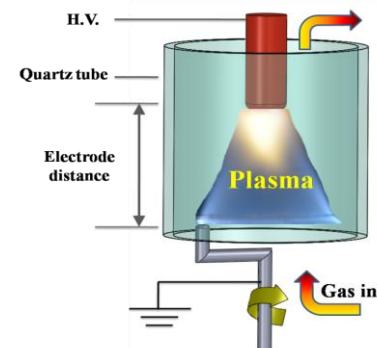

Fig.4 a new spark-shade plasma reactor

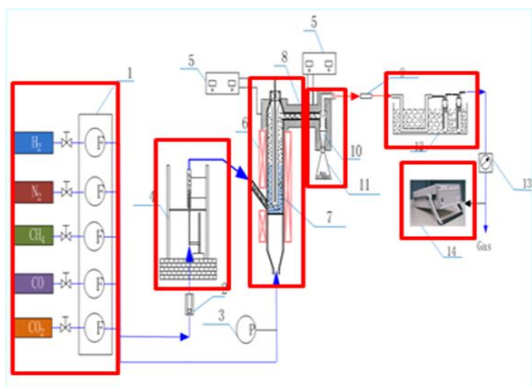

Fig.5 One powder-particle fluidized bed



Fig.6 A pilot-scale equipment for coal pretreatment for catalytic depolymerization



Fig.7 A Soxhlet extraction equipment



Fig.8 An experimental equipment for tar separation

### 5-2 Synergy from the Collaboration

There is abundant coal over the world as compared with other fossile fuels. So, coal utilization has been increased rapidly by its economic feasibility. In the joint project, we proposed an innovative method from coal to power and oils with highly energy efficient way. The achievement of this work were benefit to the increase of energy capacities, contributing to the sustainable development of Japanese and China economy, energy security.

### 5-3 Potential Impacts on Society

China has abundant coal as compared with other fossile fuels. At the same time, Chinese economics are rapidly developing, leading to shortage of energy. On the other hand, Japan has much knowledge and experience about coal utilization. In this research, the investigators in these two contries were collaborated to develop a new energy system from coal to power and oils. After that, they not only proposed a new system but also get new patents to handle these technologies in advance with other countries. As a result, these two countries economically develop together.



# 共同研究における研究成果リスト(日中共同研究:堤・黄課題)

## 1 論文発表等 Publication of Articles etc.

### 1.1 原著論文(相手側研究チームとの共著論文)

#### Original Publications (Articles co-authored with the Partner Research Teams)

年度	全著者名、題目、掲載誌名、巻、号、ページ、発行年	和文／ 英文
2013	Malinee Kaewpanha, Guoqing Guan, Xiaogang Hao, Zhongde Wang, Yutaka Kasai, Seiji Kakuta, Kastuki Kusakabe, Abuliti Abudula,66. Steam reforming of tar derived from the steam pyrolysis of biomass over metal catalyst supported on zeolite,Journal of the Taiwan Institute of Chemical Engineers,Vol.44, No.6, pp.1022-1026, 2013.	英文
2013	Qi S C, Wei X Y, Zong Z M, Hayashi J I, Yuan X H, Sun L B. A highly active Ni/ZSM-5 catalyst for complete hydrogenation of polymethylbenzenes. ChemCatChem, 5 (12): 3543-3547, 2013	英文
2014	Yufei Ma Guoqing Guan, Xiaogang Hao Zhijun Zuo Wei Huang Patchiya Phanthong, Katsuki Kusakabe and Abuliti Abudula , Highly-efficient steam reforming of methanol over copper modified molybdenum carbide.RSC Advances, 4(83) 44175-44184, 2014	英文
2014	Jenny Rizkiana,Guoqing Guan, Wahyu Bambang Widayatno, Xiaogang Hao, Xiumin Li, Wei Huang, Abuliti Abudula,Promoting effect of various biomass ashes on the steam gasification of low-rank coal.Applied Energy,133:282-288,2014	英文
2014	Jenny Rizkiana, Guoqing Guan*, Wahyu Bambang Widayatno, Xiaogang Hao, Wei Huang, Atsushi Tsutsumi, Abuliti Abudula, Effect of biomass type on the performance of cogasification of low rank coal with biomass at relatively low temperatures.Fuel,2014,134:414-419.	英文
2014	Wahyu Bambang Widayatno, Guoqing Guan*, Jenny Rizkiana, Xiaogang Hao, Zhongde Wang, Chantip Samart, Abuliti Abudula, Effect of biomass type on the performance of cogasification of low rank coal with biomass at relatively low temperatures.Fuel,2014, 132:204-210.	英文
2014	Yufei Ma, Guoqing Guan*, Patchiya Phanthong, Xiaogang Hao, Wei Huang, Atsushi Tsutsumi, Katsuki Kusakabe, Abuliti Abudula, Catalytic activity and stability of nickel-modified molybdenum carbide catalysts for steam reforming of methanol.Journal of Physical Chemistry C,2014,118(18):9485-9496.	英文
2014	Malinee Kaewpanha, Guoqing Guan*, Xiaogang Hao, Zhongde Wang, Yutaka Kasai, Katsuki Kusakabe, Abuliti Abudula Steam co-gasification of brown seaweed and land-based biomass.Fuel Processing Technology , 2014, 120:106-112.	英文
2014	Yufei Ma, Guoqing Guan*, Chuan Shi*, Aimin Zhu, Xiaogang Hao, Zhongde Wang, Katsuki Kusakabe, Abuliti Abudula,Low-temperature steam reforming of methanol to produce hydrogen over various metal-doped molybdenum carbide catalysts.International Journal of Hydrogen Energy,2014,39:258-266.	英文
2014	Cai-sheng Dai, Liang-liang Liu, Song-jiang Ma, Guo-qing Guan. "Application of lignite semi-coke on modifying and deep concentrated dewatering of sludge", Journal of China Coal Society, Vol.39, No.7, pp1361-1365, 2014.	その他
2014	Jing-Pei Cao, Peng Shi, Xiao-Yan Zhao, Xian-Yong Wei,Takayuki Takarada. "Decomposition of NO x Precursors during Gasification of Wet and Dried Pig Manures and Their Composts over Ni-based Catalysts", Energy & Fuels, Vol. 28, pp2041-2046. 2014a	英文
2014	Xiao-Yan Zhao, Shan-Shan Huang, Jing-Pei Cao, Xian-Yong Wei, Kazushi Magarisawa,Takayuki Takarada. "HyperCoal-derived porous carbons with alkaline hydroxides and carbonate activation for electric double-layer capacitors"Fuel Processing Technology, Vol. 125, pp251-257. 2014	英文
2014	Cao J P, Shi F, Zhao X Y, Wei X Y, Takarada T. Decomposition of NOx precursors during gasification of wet and dried pig manures and their composts over Ni-based catalysts. Energy & Fuels, 28 (3): 2041-2046, 2014	英文

2014	Zhao X Y, Huang S S, Cao J P, Wei X Y, Magarisawa K, Takarada T. HyperCoal-derived porous carbons with alkaline hydroxides and carbonate activation for electric double-layer capacitors. <i>Fuel Processing Technology</i> , 125: 251-257, 2014	英文
2014	Cao J P, Shi F, Zhao X Y, Wei X Y, Takarada T. Catalytic reforming of volatiles and nitrogen compounds from sewage sludge pyrolysis to clean hydrogen and synthetic gas over a nickel catalyst. <i>Fuel Processing Technology</i> , , 123: 34-40,2014	英文
2014	Xin Huang, Jing-Pei Cao, Peng Shi, Xiao-Yan Zhao, Xiao-Bo Feng, Yun-Peng Zhao, Xing Fan, Xian-Yong Wei, Takayuki Takarada. "Influences of pyrolysis conditions in the production and chemical composition of the bio-oils from fast pyrolysis of sewage sludge", <i>Journal of Analytical and Applied Pyrolysis</i> , Vol. 110. pp353-362. 2014	英文
2014	Cao J P, Huang X, Zhao X Y, Wang B S, Meesuk S, Sato K, Wei X Y, Takarada T. Low-temperature catalytic gasification of sewage sludge-derived volatiles to produce clean H <sub>2</sub> -rich syngas over a nickel loaded on lignite char. <i>International Journal of Hydrogen Energy</i> , 39 (17): 9193-9199, 2014	英文
2015	Zhao-Hui Chen, Deng-Guo Lai, Methane-rich syngas production in an integrated fluidized bed by coupling pyrolysis and gasification of low-rank coal. <i>Fuel Processing Technology</i> , 2015, 140: 88-95.	英文
2015	Litong Liang, Wei Huang, Fuxing Gao, Xiaogang Hao, Zhonglin Zhang, Qian Zhang, Guoqing Guan. "Mild catalytic depolymerization of low rank coals: a novel way to increase tar yield", <i>RSC Advances</i> , Vol. 5, pp2493-2503. 2015	英文
2015	Yufei Ma, Guoqing Guan*, Xiaogang Hao, Zhijun Zuo, Wei Huang, Patchiya Phanthong, , Xiumin Li, Katsuki Kusakabe, Abuliti Abudula, Embedded structure catalyst: a new perspective from noble metal supported on molybdenum carbide, <i>RSC Advances</i> , Vol.5, No.20, pp.15002-15005,2015	英文
2015	Wahyu Bambang Widayatno, Guoqing Guan, Jenny Rizkiana, Xiao Du, Xiaogang Hao, Zhonglin Zhang, Abuliti Abudula, Selective catalytic conversion of bio-oil over high-silica zeolites, <i>Bioresource Technology</i> , Vol.179, pp.523-528,2015	英文
2015	Surachai Karnjanakom, Guoqing Guan*, Bayu Asep, Xiao Du, Xiaogang Hao, Chantip Samart, Abuliti Abudula, Catalytic steam reforming of tar derived from steam gasification of sunflower stalk over ethylene glycol assisting prepared Ni/MCM-41, <i>Energy Conversion and Management</i> , Vol.98, pp.359-368,2015	英文
2015	Cao J P, Huang X, Zhao X Y, Wei X Y, Takarada T. Nitrogen transformation during gasification of livestock compost over transition metal and Ca-based catalysts. <i>Fuel</i> , 140: 477-483, 2015	英文
2015	Yang H M, Zhao W, Norinaga K, Fang J J, Wang Y G, Zong Z M, Wei X Y Separation of phenols and ketones from bio-oil produced from ethanolysis of wheat stalk. <i>Separation and Purification Technology</i> , 152: 238-245, 2015	英文
2015	Malinee Kaewpanha, Guoqing Guan *, Yufei Ma, Xiaogang Hao, Zhonglin Zhang, Prasert Reubroychareon, Katsuki Kusakabe, Abuliti Abudula, Hydrogen production by steam reforming of biomass tar over biomass char supported molybdenum carbide catalyst, <i>International Journal of Hydrogen Energy</i> , Vol. 40, No.25, pp.7974-7982. 2015	英文
2015	Jenny Rizkiana, Guoqing Guan*, Wahyu Bambang Widayatno, Xiaogang Hao, Zhongde Wang, Zhonglin Zhang, Abuliti Abudula, Oil production from mild pyrolysis of low-rank coal in molten salts media, <i>Applied Energy</i> , Vol.154, pp.944-950,2015	英文
2015	Cao J P, Huang X, Zhao X Y, Wei X Y, Takarada T. Nitrogen transformation during gasification of livestock compost over transition metal and Ca-based catalysts. <i>Fuel</i> , 140: 477-483, 2015	英文
2015	Hua-Mei Yang, Wei Zhao, Koyo Norinaga, Jun-Ji Fang, Yu-Gao Wang, Zhi-Min Zong, Xian-Yong Wei, Separation of phenols and ketones from bio-oil produced from ethanolysis of wheat stalk. <i>Separation and Purification Technology</i> , 152, 238-245 (2015)	英文
2015	Surachai Karnjanakom, Guoqing Guan*, Bayu Asep, Xiao Du, Xiaogang Hao, Jingxuan Yang, Chantip Samart and Abuliti Abudula, 109. A green way to increase yield and quality of bio-oil: ultrasonic pretreatment of biomass and catalytic upgrading of bio-oil over metal (Cu, Fe and/or Zn)/ $\gamma$ -Al <sub>2</sub> O <sub>3</sub> , <i>RSC Advances</i> , Vol.5, pp.83494-83503, 2015	英文
2015	Jenny Rizkiana, Guoqing Guan*, Wahyu B. Widayatno, Jingxuan Yang, Xiaogang Hao, Koichi Matsuoka, Abuliti Abudula, Mg-modified ultra-stable Y type zeolite for the rapidly catalytic copyrolysis of low-rank coal and biomass, <i>RSC Advances</i> , Vol.6, pp.2096-2105.2016	英文

2015	Wahyu Bambang Widayatno, Guoqing Guan*, Jenny Rizkiana, Jingxuan Yang, Xiaogang Hao, Atsushi Tsutsumi, and Abuliti Abudula, Upgrading of bio-oil from biomass pyrolysis over Cu-modified $\beta$ -zeolite catalyst with high selectivity and stability, Applied Catalysis B: Environmental Vol.186, pp.166-172, 2016	英文
2015	Ji Cao, Yufei Ma, Guoqing Guan*, Xiaogang Hao, Xuli Ma, Zhongde Wang, Katsuki Kusakabe, Abuliti Abudula, Reaction intermediate species during the steam reforming of methanol over metal modified molybdenum carbide catalysts, Applied Catalysis B: Environmental, Vol.189, pp.12-18, 2016	英文
2015	Guoqing Guan *, Malinee Kaewpanha, Xiaogang Hao, Abuliti Abudula, Catalytic steam reforming of biomass tar: Prospects and challenges, Renewable & Sustainable Energy Reviews, Vol. 58 pp.450-461, 2016	英文
2015	Jingxuan Yang, Malinee Kaewpanh, Surachai Karnjanakom, Guoqing Guan*, Xiaogang Hao, Abuliti Abudula. Steam reforming of biomass tar over calcined egg shell supported catalysts for hydrogen production, International Journal of Hydrogen Energy, 41, 6699-6705, 2016	英文
2015	Jenny Rizkiana, Guoqing Guan*, Wahyu B. Widayatno, Jingxuan Yang, Xiaogang Hao, Koichi Matsuoka, Abuliti Abudula, Mg-modified ultra-stable Y type zeolite for the rapidly catalytic copyrolysis of low-rank coal and biomass, RSC Advances, Vol.6, pp.2096-2105, 2016	英文
2015	Surachai Karnjanakom, Guoqing Guan,* Bayu Asep, Xiaogang Hao, Suwadee Kongparakul, Chanatip Samart, and Abuliti Abudula. Catalytic upgrading of bio-oil over Cu/MCM-41 and Cu/KIT-6 prepared by $\beta$ -Cyclodextrin-assisted coimpregnation method, Journal of Physical Chemistry C, 120(6), 3396-3407, 2016	英文

### 1. 2. 1 原著論文(相手側研究チームを含まない日本側研究チームの論文)

#### Original Publications (Articles by the Japanese Research Teams only, excluding the Partner Research Teams)

年度	全著者名、題目、掲載誌名、巻、号、ページ、発行年	和文／英文
2013	Li-xin Zhang, Toru Matsuhara, Shinji Kudo, Jun-ichiro Hayashi, Koyo Norinaga, Rapid pyrolysis of brown coal in a drop-tube reactor with co-feeding of char as a promoter of in situ tar reforming. Fuel, 112:681-686(2013)	英文
2013	Sirimirin Meesuk, Jing-Pei Cao, Kazuyoshi Sato, Akihiro Hoshino, Kazuhiko Utsumi and Takayuki Takarada, "Nitrogen Conversion of Pig Compost during Pyrolysis", Journal of Chemical Engineering of Japan, 46[8], 556-561 (2013)	英文
2013	Sirimirin Meesuk, Kazuyoshi Sato, Jing-Pei Cao, Akihiro Hoshino, Kazuhiko Utsumi and Takayuki Takarada. "Catalytic reforming of nitrogen-containing volatiles evolved through pyrolysis of composted pig manure". Bioresource Technology, 150, 181-186 (2013)	英文
2013	Liu-Yun Li and Takayuki Takarada, "Conversion of nitrogen compounds and tars obtained from pre-composted pig manure pyrolysis, over nickel loaded brown coal char", Biomass and Bioenergy, 56, 456-463 (2013)	英文
2013	森勝伸、上村卓寛、郡司文音、金子啓一、佐藤和好、宝田恭之、板橋英之、"家畜排せつ物コンポストの低温ガス化プロセスにおける硫黄及び塩素の放出挙動の分析と固体残渣の脱硫・脱塩への応用"、分析化学, 62[10], 915-924 (2013)	和文
2013	Yuji Yoshie, Masanori Ishizuka, Guoqing Guan, Chihiro Fushimi, Atsushi Tsutsumi, "A novel experimental technique to determine the heat transfer coefficient between the bed and particles in a downer," Advanced Powder Technology, 24 (2013) 487-494	英文
2014	堀口 和哉、佐藤 和好、宝田 恭之、"BaSnO3の形態がタール改質活性に及ぼす影響"、粉体工学会誌, 51[3], 169-173 (2014)	和文
2014	Jing-Pei Cao, Peng Shi, Xiao-Yan Zhao, Xian-YongWei, Takayuki Takarada, "Catalytic reforming of volatiles and nitrogen compounds from sewage sludge pyrolysis to clean hydrogen and synthetic gas over a nickel catalyst", Fuel Processing Technology, 123, 34-40 (2014)	英文

2014	Cheewasu Phuhiran, Takayuki Takarada, Suparin Chaiklangmuang, "Hydrogen-rich gas from catalytic steam gasification of eucalyptus using nickel-loaded Thai brown coal char catalyst", International Journal of Hydrogen Energy, 39[8], 3649-3656 (2014)	英文
2014	Jing-Pei Cao, Xin Huang, Xiao-Yan Zhao, Ben-Shui Wang, Sirimirin Meesuk, Kazuyoshi Sato, Xian-Yong Wei, Takayuki Takarada, "Low-temperature catalytic gasification of sewage sludge-derived volatiles to produce clean H <sub>2</sub> -rich syngas over a nickel loaded on lignite char", International Journal of Hydrogen Energy, 39[17], 9193-9199 (2014)	英文
2014	Xin Huang, Jing-Pei Cao, Peng Shi, Xiao-Yan Zhao, Xiao-Bo Feng, Yun-Peng Zhao, Xing Fan, Xian-Yong Wei, Takayuki Takarada, "Influences of pyrolysis conditions in the production and chemical composition of the bio-oils from fast pyrolysis of sewage sludge", Journal of Analytical and Applied Pyrolysis, 110, 353-362 (2014)	英文
2014	Keiichi Kaneko, Liuyun Li, Tadaaki Shimizu, Hideyuki Matsumura and Takayuki Takarada, "Fuel gas production and plant nutrient recovery from digested poultry manure", J. Poultry Science, 51[4] 444-452 (2014)	英文
2014	Yasumasa Kawabata, Takaaki Wajima, Hideki Nakagome, Sou Hosokai, Yoshizo Suzuki, and Koichi Matsuoka, "Reduction and Reforming of Tar with Enhancing Volatile-char Interaction during Coal Pyrolysis", International Journal of Chemical Engineering and Applications, 6(4) 281-284 (2014).	英文
2014	Koyo Norinaga, Huamei Yang, Ryota Tanaka, Srinivas Appari, Keita Iwanaga, Yuka Takashima, Shinji Kudo, Tetsuya Shoji, Jun-ichiro Hayashi. A mechanistic study on the reaction pathways leading to benzene and naphthalene in cellulose vapor phase cracking. Biomass and Bioenergy, Volume 69, October 2014, Pages 144-154	英文
2014	Huamei Yang, Srinivas Appari, Shinji Kudo, Jun-ichiro Hayashi, Satoshi Kumagai, and Koyo Norinaga. Chemical structures and primary pyrolysis characteristics of lignins obtained from different preparation methods. Journal of the Japan Institute of Energy, 93, 986-994 (2014)	英文
2014	Yong Huang, Hajime Sakamoto, Shinji Kudo, Koyo Norinaga, Jun-ichiro Hayashi. Pyrolysis of Lignite with Internal Recycling and Conversion of Oil. Energ. Fuels, 2014, 28 (11), pp 7285-7293	英文
2015	Qingxin Zheng, Masato Morimoto, Toshimasa Takanohashi, An efficient production of benzene from benzoic acid in subcritical water using a copper (I) oxide catalyst, Green Chemistry, 17, 791-794 (2015)	英文
2015	Qingxin Zheng, Masato Morimoto, Hiroaki Sato, Toshimasa Takanohashi, Molecular composition of extracts obtained by hydrothermal extraction of brown coal, Fuel, 159, 751-758 (2015)	英文
2015	Jing-Pei Cao, Xin Huang, Xiao-Yan Zhao, Xian-Yong Wei, Takayuki Takarada, "Nitrogen transformation during gasification of livestock compost over transition metal and Ca-based catalysts", Fuel, 140, 477-483 (2015)	英文
2015	Ben-Shui Wang, Jing-Pei Cao, Xiao-Yan Zhao, Yue Bian, Chong Song, Yun-Peng Zhao, Xing Fan, Xian-Yong Wei, Takayuki Takarada, "Preparation of nickel-loaded on lignite char for catalytic gasification of biomass", Fuel Processing Technology, 136, 17-24 (2015)	英文
2015	Suparin Chaiklangmuang, Keisuke Kurosawa, Liuyun Li, Kayoko Morishita, Takayuki Takarada, "Thermal Degradation behavior of coffee Residue Comparison with Biomasses and its Product Yields from Gasification", Journal of the Energy Institute, 88 [3], 323-331 (2015)	英文
2015	B. Kongsomart, N. Kannari and T. Takarada, "Catalytic effects of biomass-derived ash on Loy Yang brown coal gasification", International Journal of Biomass and Renewables	英文
2015	Srinivas Appari; Ryota Tanaka; Chengyi Li; Shinji Kudo; Jun-ichiro Hayashi; Vinod M Janardhanan; Hiroaki Watanabe; Koyo Norinaga. Predicting Temperature and Reactant Concentration Profiles of Reacting Flow in Partial Oxidation of Hot Coke Oven Gas with Detailed Chemistry and One Dimensional Flow Model. Chem Eng J, Volume 266, 15 April 2015, Pages 82-90	英文

2015	Narumon Thimthong, Srinivas Appari, Ryota Tanaka, Keita Iwanaga, Shinji Kudo, Jun-ichiro Hayashi, Tetsuya Shoji, and Koyo Norinaga. Kinetic Modeling of Non-Catalytic Partial Oxidation of Nascent Volatiles Derived from Fast Pyrolysis of Woody Biomass with Detailed Chemistry. Fuel Processing Technology, 134, 159-167 (2015)	英文
2015	Uemura Kazuhiro; Appari Srinivas; Shinji Kudo; Jun-ichiro Hayashi; Hisahiro Einaga; Koyo Norinaga. In-situ reforming of the volatiles from fast pyrolysis of ligno-cellulosic biomass over zeolite catalysts for aromatic compound production. Fuel Processing Technology, Volume 136, August 2015, Pages 73-78	英文
2015	Narumon Thimthong, Srinivas Appari, Ryota Tanaka, Keita Iwanaga, Tomoaki Namioka, Shinji Kudo, Jun-ichiro Hayashi, and Koyo Norinaga, Numerical study on steam reforming of biomass tar using detailed chemical kinetic model. Journal of the Japan Institute of Energy, Vol. 94 (2015) No. 8 p. 794-804	英文
2015	Hua-Mei Yang, Srinivas Appari, Shinji Kudo, Jun-ichiro Hayashi, Koyo Norinaga. Detailed Chemical Kinetic Modeling of the Vapor-Phase Cracking of Volatiles Derived from the Fast Pyrolysis of Lignin. Industrial & Engineering Chemistry Research 54 (27), 6855-6864 (2015)	英文
2015	Chengyi Li, Srinivas Appari, Ryota Tanaka, Yeonkyung Lee, Kyoko Hanao, Shinji Kudo, Jun-ichiro Hayashi, Vinod M Janardhanan, Hiroaki Watanabe, Koyo Norinaga. A CFD Study on the Reacting Flow of Partially Combusting Hot Coke Oven Gas in a Bench Scale Reformer. Fuel, 159, 590-598(2015)	英文
2015	Cheng-Yi Li, Srinivas Appari, Li-Xin Zhang, An-Ni Huang, Hsiu-Po Kuo, Shinji Kudo, Jun-ichiro Hayashi, Koyo Norinaga. Modeling of gas/particle flow in coal conversion with a drop tube reactor using a lumped kinetic model accounting volatiles char interaction. Fuel Processing Technology, Volume 138, October 2015, Pages 588-594	英文

### 1. 2. 2 原著論文(日本側研究チームを含まない相手側研究チームの論文)

#### Original Publications (Articles by the Partner Research Teams only, excluding the Japanese Research Teams)

年度	全著者名、題目、掲載誌名、巻、号、ページ、発行年	和文／ 英文
2013	Jing-Lin Liu, Xiao-Song Li, Xiaobing Zhu, Kai Li, Chuan Shi, Ai-Min Zhu*, "Renewable and high-concentration syngas production from oxidative reforming of simulated biogas with low energy cost in a plasma shade", Chemical Engineering Journal, 2013, 234: 240-246	英文
2013	Fang-Jing Liu, Xian-Yong Wei Fang-Jing Liu, Investigation on structural features of Shengli lignite through oxidation under. Fuel 109 (2013) 316–324.	英文
2013	Shui H F, Wang W W, Cai Z Y, Wang Z C, Lei Z P, Ren S B, Pan C X, Li H P. Coliquefaction behaviours of Shenhua coal and sawdust catalysed by different catalysts. Journal of the Energy Institute, 2013, 86 (2): 107-112	英文
2013	Zhou J, Zong Z M, Fan X, Zhao Y P, Wei X Y. Separation and identification of organic compounds from thermally dissolved Shengli lignite in a methanol/benzene mixed solvent. International Journal of Oil, Gas and Coal Technology, 6 (5): 517-527, 2013	英文
2013	Shi D L, Wei X Y, Fan X, Zong Z M, Chen B, Zhao Y P, Wang Y G, Cao J P. Characterizations of the extracts from Geting bituminous coal by spectrometries. Energy & Fuels, 2013, 27 (7): 3709–3717	英文
2013	Wang Y G, Wei X Y, Yan H L, Shi D L, Liu F J, Li P, Fan X, Zhao Y P, Zong Z M. Structural features of extraction residues from supercritical methanolysis of two Chinese lignites. Energy & Fuels, 2013, 27 (8): 4632-4638	英文
2013	Liu F J, Wei X Y, Gui J, Wang Y G, Li P, Zong Z M. Characterization of biomarkers and structural features of condensed aromatics in Xianfeng lignite. Energy & Fuels, 2013, 27 (12): 7369-7378	英文

2013	Wang Y H, Wei X Y, Yue X M, Sun B, Wen Z, Lv J H, Wang S Z, Zong Z M, Fan X, Zhao Y P. The compositional features of thermally soluble fractions from two Chinese coals in cyclohexane. Energy Sources, Part A: Recovery, Utilization, and Environmental Effects, 2013, 35 (19): 1836-1844	英文
2013	Shi D L, Wei X Y, Chen B, Zong Z M, Zhao Y P, Fan X, Hou J N. The enrichment of condensed arenes in Geting bituminous coal. Energy Sources, Part A: Recovery, Utilization, and Environmental Effects, 2013, 35 (20): 1898-1904	英文
2013	Liu F J, Wei X Y, Lu Y, Qing Y, Zhu Y, Li L, Lv J, Sun B, Yue X M, Zong Z M, Zhao W. The effect of the pretreatment with H <sub>2</sub> O <sub>2</sub> on the oxidation of Shenfu coal with NaOCl. Energy Sources, Part A: Recovery, Utilization, and Environmental Effects, 35 (21): 1967-1974, 2013	英文
2013	Shi D L, Wei X Y, Chen B, Lu Y, Li L, Wang Y G, Li P, Zhao L, Zong Z M, Zhao W, Fan X, Zhao Y P. The identification of organooxygen compounds in Geting bituminous coal. Energy Sources, Part A: Recovery, Utilization, and Environmental Effects, 2013, 35 (22): 2166-2172	英文
2013	Zhou J, Zong Z M, Chen B, Yang Z S, Li P, Lu Y, Yue X M, Cong X S, Wei Y B, Wang Y G, Fan X, Zhao Y P, Hou J N, Wei X Y. The enrichment and identification of methyl alkanones from thermally soluble Shengli lignite. Energy Sources, Part A: Recovery, Utilization, and Environmental Effects, 2013, 35 (23): 2218-2224	英文
2013	Li P, Wei X Y, Sun X H, Lu Y, Zong Z M, Mukasa R, Wang Y G, Shi D L, Li L, Zhao L, Fan X, Zhao Y P, Hou J N, Liu Q C. The isolation of condensed arenes from Shenmu-Fugu coal liquefaction residue. Energy Sources, Part A: Recovery, Utilization, and Environmental Effects, 35 (23): 2250-2256, 2013	英文
2013	Wei Y B, Wei X Y, Yu L C, Li P, Zong Z M, Zhao W. The amorphous alloy-catalyzed hydroconversion of demineralized Shengli coal liquefaction residue under microwave irradiation. Energy Sources, Part A: Recovery, Utilization, and Environmental Effects, 2013, 35 (24): 2302-2309	英文
2013	Wei Y B, Wei X Y, Zong Z M, Zhao W, Han X E. The zeolite-catalyzed hydroconversion of demineralized Shengli lignite liquefaction residue under microwave irradiation. Energy Sources, Part A: Recovery, Utilization, and Environmental Effects, 2013, 35 (24): 2310-2318	英文
2013	Wang Y G, Wei X Y, Lu H Y, Yao T, Robert M, Yang H M, Li P, Li L, Wen Z, Zong Z M. Separation and analysis of the products from supercritical ethanolysis of Huolinguole lignite. Energy Sources, Part A: Recovery, Utilization, and Environmental Effects, 35 (24): 2319-2327, 2013	英文
2013	Liu F J, Wei X Y, Zhu Y, Fan X, Gui J, Wang Y G, Zhao Y P, Zong Z M, Zhao W. Investigation on structural features of Shengli lignite through oxidation under mild conditions. Fuel, 2013, 109: 316-324	英文
2013	Liu F J, Wei X Y, Zhu Y, Wang Y G, Li P, Fan X, Zhao Y P, Zong Z M, Zhao W, Wei Y B. Oxidation of Shengli lignite with aqueous sodium hypochlorite promoted by pretreatment with aqueous hydrogen peroxide. Fuel, 2013, 111: 211-215	英文
2014	Wang Y G, Wei X Y, Yan H L, Zong Z M. Identification of organic nitrogen compounds from thermally dissolved Huolinguole lignite with ethanol. International Journal of Oil, Gas and Coal Technology, 8 (1): 93-103, 2014	英文
2014	Yang Z S, Zong Z M, Chen B, Liu C, Zhao Y P, Fan X, Wei X Y, Hayashi J I. Thermal dissolution of Shengli lignite in ethyl acetate. International Journal of Oil, Gas and Coal Technology, 2014, 7 (3): 308-321	英文
2014	Yu L C, Wei X Y, Wang Y H, Wen Z, Zhang D D, Zong Z M, Fan X, Zhao Y P. Catalytic hydroconversion of Lingwu bituminous coal over Fe-S/□-Al <sub>2</sub> O <sub>3</sub> . International Journal of Oil, Gas and Coal Technology, 2014, 7 (4): 415-430	英文
2014	MingSun, JingChen, Xiao-minDai, Xiang-longZhao, KeLiu, Xiao-xunMa, Controlled Separation of Low Temperature Coal Tar Based on Solvent Extraction-Column Chromatography. Fuel Processing Technology. 13641-49, 2014	英文

2014	Zheng A L, Fan X, Wang S Z, Liu F J, Wei X Y, Zhao Y P, Zong Z M, Zhao W, Chen L, You C Y, Zhu J L. Analysis of the products from the oxidation of getting bituminous coal by atmospheric pressure photoionization–mass spectrometry. <i>Analytical Letters</i> , 47 (6): 958-969, 2014	英文
2014	Liu F J, Wei X Y, Xie R L, Wang Y G, Li W T, Li Z K, Li P, Zong Z M. Characterization of oxygen-containing species in methanolysis products of extraction residue from Xianfeng lignite with negative-ion electrospray ionization Fourier transform ion cyclotron resonance mass spectrometry. <i>Energy &amp; Fuels</i> , 2014, 28 (9): 5596-5605	英文
2014	Cong X S, Zong Z M, Zhou Y, Li M, Wang W L, Li F G, Zhou J, Fan X, Zhao Y P, Wei X Y. Isolation and identification of 3-ethyl-8-methyl-2,3-dihydro-1H-cyclopenta[a]chrysene from Shengli lignite. <i>Energy &amp; Fuels</i> , 28 (10): 6694-6697, 2014	英文
2014	Fan X, Chen L, Wang S Z, Qing Y, Wei X Y, Zhao Y P, Zheng A L, Zhu J L, You C Y. Analysis of Getting bituminous coal by electrospray ionization and direct analysis in real time mass spectrometry. <i>Analytical Letters</i> , 47 (12): 2012-2022, 2014	英文
2014	Ding M, Zhao Y P, Zhu Y Y, , Zong Z M, Wei X Y, Fan X. The identification of soluble nitrogen-containing organic species in two Chinese lignites. <i>Energy Sources, Part A: Recovery, Utilization, and Environmental Effects</i> , 36 (18): 2027-2032, 2014	英文
2014	Yao T, Zong Z M, Wei X Y. Identification of organonitrogen compounds in petroleum ether-soluble fraction from a high-temperature coal tar. <i>Energy Sources, Part A: Recovery, Utilization, and Environmental Effects</i> , 36 (21): 2383-2391, 2014	英文
2014	Qi S C, Zhang L, Wei X Y, Hayashi J I, Zong Z M, Guo L L. Deep hydrogenation of coal tar over Ni/ZSM-5 catalyst. <i>RSC Advances</i> , 4 (33): 17105-17109, 2014	英文
2014	Shui H F, Yang L, Shui T, Pan C X, Li H P, Wang Z C, Lei Z P, Ren S B, Kang S G. Hydro-liquefaction of thermal dissolution soluble fraction of Shenfu subbituminous coal and reusability of catalyst on the hydro-liquefaction. <i>Fuel</i> , 115: 227–231, 2014	英文
2014	Shui H F, Zhao W J, Shan C J, Shui T, Pan C X, Wang Z C, Lei Z P, Ren S B, Kang S G. Caking and coking properties of the thermal dissolution soluble fraction of a fat coal. <i>Fuel Processing Technology</i> , 118: 64–68, 2014	英文
2014	Wang S Z, Fan X, Zheng A L, Wang Y G, Dou Y Q, Wei X Y, Zhao Y P, Wang R Y, Zong Z M, Zhao W. Evaluation of atmospheric solids analysis probe mass spectrometry for the analysis of coal-related model compounds. <i>Fuel</i> , 117: 556-563, 2014	英文
2014	Li Z K, Zong Z M, Yan H L, Wang Y G, Wei X Y, Shi D L, Zhao Y P, Zhao C L, Yang Z S, Fan X. Alkanolysis simulation of lignite-related model compounds using density functional theory. <i>Fuel</i> , 120: 158-162, 2014	英文
2014	Yu L C, Wei X Y, Wang Y H, Zhang D D, Wen Z, Zong Z M, Fan X, Zhao Y P, Zhao W, Zhu Y L. Catalytic hydroconversion of extraction residue from Shengli lignite over Fe-S/ZSM-5. <i>Fuel Processing Technology</i> , 126: 131-137, 2014	英文
2014	Liu F J, Wei X Y, Gui J, Li P, Wang Y G, Li W T, Zong Z M, Fan X, Zhao Y P. Characterization of organonitrogen species in Xianfeng lignite by sequential extraction and ruthenium ion-catalyzed oxidation. <i>Fuel Processing Technology</i> , 2014, 126: 199-206	英文
2014	Li Z K, Zong Z M, Yan H L, Wang Y G, Ni H X, Wei X Y, Li Y H. Characterization of acidic species in ethanol-soluble portion from Zhaotong lignite ethanolysis by negative-ion electrospray ionization Fourier transform ion cyclotron resonance mass spectrometry. <i>Fuel Processing Technology</i> , 128: 297-302, 2014	英文
2014	Lv J H, Wei X Y, Wang Y H, Yu L C, Zhang D D, Yue X M, Zong Z M, Fan X, Zhao Y P. Light fraction from catalytic hydroconversion of two Chinese coals in cyclohexane over a solid acid. <i>Fuel Processing Technology</i> , 129: 162-167, 2014	英文

2014	Jiangze Han, Xiaoxing Liu, Junrong Yue, Bingfeng Xi, Shiqiu Gao, Guangwen Xu, Catalytic upgrading of in situ coal pyrolysis tar over Ni-char catalyst with different additives. <i>Energy &amp; Fuels</i> , 2014, 28(8), 4934-4941.	英文
2014	Jinhui Zhan, Rongcheng Wu, Xiaoxing Liu, Shiqiu Gao, Guangwen Xu, Preliminary understanding of initial reaction process for subbituminous coal pyrolysis with molecular dynamics simulation. <i>Fuel</i> , 2014, 134: 283-292.	英文
2014	Zhigang Zhao, Juwei Zhang, Guangyi Zhang, Xi Zeng, Xiaoxing Liu, Guangwen Xu, Hydrodynamic characterization of a tapered gas–solid bed without a gas distributor. <i>Powder Technology</i> , 2014, 256: 300-309.	英文
2014	Zhigang Zhao, Juwei Zhang, Feixiang Zhao, Xi Zeng, Xiaoxing Liu, Guangwen Xu, Destruction of caking properties of bituminous coal by jetting pre-oxidation in a fluidized bed. <i>Fuel</i> , 2014, 133, 45-51.	英文
2014	曾令鹏, 谢放华, 韩江则, 周琦, 高士秋*, 许光文, 多层床煤热解提高油气品质的机理研究. <i>煤炭转化</i> , 2014, 37(1): 55-60.	その他
2014	Chan Dong, Lijun Jin, Yang Li, Yang Zhou, Liang Zou, Haoquan Hu, Integrated Process of Coal Pyrolysis with Steam Reforming of Methane for Improving the Tar Yield. <i>Energy Fuels</i> 2014, 28 (12), 7377–7384.	英文
2014	Lijun Jin, Yang Li, Ping Lin, Haoquan Hu, CO <sub>2</sub> reforming of methane on Ni/ $\gamma$ -Al <sub>2</sub> O <sub>3</sub> catalyst prepared by dielectric barrier discharge hydrogen plasma. <i>International Journal of Hydrogen Energy</i> , 2014, 39(11): 5766-5763.	英文
2014	Long Xu, Mingchen Tang, Lin'e Duan, Baolin Liu, Xiaoxun Ma, Yulong Zhang, Morris D. Argyle, Maohong Fan Pyrolysis characteristics and kinetics of residue from China Shenhua industrial direct coal liquefaction plant. <i>Thermochimica Acta</i> , 2014, 589 : 1-10.	英文
2014	杜鹏鹏, 孙鸣, 陕北中低温煤焦油常压重油馏分的GC-MS分析(II). <i>化学工程</i> , 42(3):59-63, 2014.	英文
2014	Xiaobing Zhu*, Kai Li, Jing-Lin Liu, Xiao-Song Li, Ai-Min Zhu*, "Effect of CO <sub>2</sub> /CH <sub>4</sub> ratio on biogas reforming with added O <sub>2</sub> through an unique spark-shade plasma", <i>International Journal of Hydrogen Energy</i> , 2014, 39: 19902-13908	英文
2015	Shui H F, Zhu W W, Wang W W, Pan C X, Wang Z C, Lei Z P, Ren S B, Kang S G. Thermal dissolution of lignite and liquefaction behaviors of its thermal dissolution soluble fractions. <i>Fuel</i> , 139: 516-522, 2015	英文
2015	Shui H F, Hui Z, Jiang Q Q, Zhou H, Pan C X, Wang Z C, Lei Z P, Ren S B, Kang S G. Co-thermal dissolution of Shenmu-Fugu subbituminous coal and sawdust. <i>Fuel Processing Technology</i> , 131: 87-92, 2015	英文
2015	Shui H F, He F, Wu Y, Pan C X, Wang Z C, Lei Z P, Ren S B, Kang S G. Study on the use of the thermal dissolution soluble fraction from Shenfu sub-bituminous coal in coke-making coal blends. <i>Energy &amp; Fuels</i> , 29 (3): 1558-1563, 2015	英文
2015	Wang Y G, Wei X Y, Xie R L, Liu F J, Li P, Zong Z M. Structural characterization of typical organic species in Jincheng No.15 anthracite. <i>Energy &amp; Fuels</i> , 29 (2): 595-601, 2015	英文
2015	Yao J H, Wei X Y, Xiao L, Zong Z M, Liu F J. Fractional extraction and biodepolymerization of Shengli lignite. <i>Energy &amp; Fuels</i> , 29 (3): 2014-2021, 2015	英文



2015	Xie R L, Zong Z M, Wang W L, Yan H L, Fan X, Wei Z H, Mayyas M, Wei X Y. Characterization of volatiles in coal tar pitch by gas chromatography/mass spectrometry and atmospheric pressure solid analysis probe/time of flight-mass spectrometry. <i>Analytical Letters</i> , 48 (6): 955-965, 2015	英文
2015	Li Z K, Wei X Y, Yang Z S, Yan H L, Wei Z H, Li Y, Zong Z M. Characterization of extracts from Geting bituminous coal. <i>Analytical Letters</i> , 48 (9): 1494-1501, 2015	英文
2015	Liu F J, Wei X Y, Wang Y G, Li P, Li Z K, Zong Z M. Sulfur-containing species in the extraction residue from Xianfeng lignite characterized by X-ray photoelectron spectrometry and electrospray ionization Fourier transform ion cyclotron resonance mass spectrometry. <i>RSC Advance</i> , 5 (10): 7125-7130, 2015	英文
2015	Li Z K, Wei X Y, Yan H L, Wang Y G, Kong J, Zong Z M. Advances in lignite extraction and conversion under mild conditions. <i>Energy &amp; Fuels</i> , 29 (11): 6869-6886, 2015	英文
2015	Fan X, Zhu J L, Zheng A L, Wei X Y, Zhao Y P, Cao J P, Zhao W, Lu Y, Chen L, You C Y. Rapid characterization of heteroatomic molecules in a bio-oil from pyrolysis of rice husk using atmospheric solid analysis probe mass spectrometry. <i>Journal of Analytical and Applied Pyrolysis</i> , 115: 16-23, 2015	英文
2015	Lei Z P, Cheng L L, Zhang S F, Zhang Y Q, Shui H F, Ren S B, Wang Z C. Dissolution performance of coals in ionic liquid 1-butyl-3-methyl-imidazolium chloride. <i>Fuel Processing Technology</i> , 129: 222-226, 2015	英文
2015	Li P, Zong Z M, Li Z K, Wang Y G, Liu F J, Wei X Y. Characterization of basic heteroatom compounds in liquefaction residue from Shenmu-Fugu subbituminous coal by positive-ion electrospray ionization Fourier transform ion cyclotron resonance mass spectrometry. <i>Fuel Processing Technology</i> , 132: 91-98, 2015	英文
2015	Zhang D D, Zong Z M, Liu J, Wang Y H, Yu L C, Lv J H, Wang T M, Wei X Y, Wei Z H, Li Y. Catalytic hydroconversion of Geting bituminous coal over FeNi-S/ $\gamma$ -Al <sub>2</sub> O <sub>3</sub> . <i>Fuel Processing Technology</i> , 133: 195-201, 2015	英文
2015	Cong X S, Zong Z M, Li M, Gao L, Wei Z H, Li Y, Fan X, Zhou Y, Wei X Y. Enrichment and identification of cyclized hopanoids from Shengli lignite. <i>Fuel Processing Technology</i> , 134: 399-403, 2015	英文
2015	Ding M, Zhao Y P, Dou Y Q, Wei X Y, Fan X, Cao J P, Wang Y L, Zong Z M. Sequential extraction and thermal dissolution of Shengli lignite. <i>Fuel Processing Technology</i> , 135: 20-24, 2015	英文
2015	Lei Z P, Cheng L L, Zhang S F, Shui H F, Ren S B, Kang S G, Pan C X, Wang Z C. Dissolution of lignite in ionic liquid 1-ethyl-3-methylimidazolium acetate. <i>Fuel Processing Technology</i> , 135: 47-51, 2015	英文
2015	Li P, Zong Z M, Liu F J, Wang Y G, Wei X Y, Fan X, Zhao Y P, Zhao W. Sequential extraction and characterization of liquefaction residue from Shenmu-Fugu subbituminous coal. <i>Fuel Processing Technology</i> , 136: 1-7, 2015	英文
2015	Liu F J, Wei X Y, Li W T, Gui J, Li P, Wang Y G, Zong Z M. Methanolysis of extraction residue from Xianfeng lignite with NaOH and product characterizations with different spectrometries. <i>Fuel Processing Technology</i> , 136: 8-16, 2015	英文
2015	Wang B S, Cao J P, Zhao X Y, Bian Y, Song C, Zhao Y P, Fan X, Wei X Y, Takarada T. Preparation of nickel-loaded on lignite char for catalytic gasification of biomass. <i>Fuel Processing Technology</i> , 136: 17-24, 2015	英文
2015	Wang Y G, Wei X Y, Yan H L, Liu J, Li P, Liu F J, Zong Z M. Oxidation of Shenmu char powder with aqueous hydrogen peroxide-acetic anhydride. <i>Fuel Processing Technology</i> , 136: 56-63, 2015	英文

2015	Wang Z C, Ge Y, Shui H F, Ren S B, Pan C X, Kang S G, Lei Z P, Zhao Z J, Hu J C. Molecular structure and size of asphaltene and preasphaltene from direct coal liquefaction. Fuel Processing Technology, 137: 305-311, 2015	英文
2015	Zhu J L, Fan X, Wei X Y, Wang S Z, Zhu T G, Zhou C C, Zhao Y P, Wang R Y, Lu Y, Chen L, You C Y. Molecular characterization of heteroatomic compounds in high-temperature coal tar using three mass spectrometers. Fuel Processing Technology, 138: 65-73, 2015	英文
2015	Wang T M, Zong Z M, Liu F J, Liu C, Lv J H, Liu J, Zhang D D, Qu M, Gui J, Liu X X, Wei X Y, Wei Z H, Li Y. Investigation on compositional and structural features of Xianfeng lignite through sequential thermal dissolution. Fuel Processing Technology, 138: 125-132, 2015	英文
2015	Lei Z P, Hu Z Q, Shui H F, Ren S B, Wang Z C, Kang S G, Pan C X. Pyrolysis of lignin following ionic liquid pretreatment at low temperature. Fuel Processing Technology, 138: 612-615, 2015	英文
2015	Li Z K, Zong Z M, Yan H L, Wei Z H, Li Y, Wei X Y. Identification of basic nitrogen compounds in ethanol-soluble portion from Zhaotong lignite ethanolysis by positive-ion electrospray ionization Fourier transform ion cyclotron resonance mass spectrometry. Fuel, 141: 268-274, 2015	英文
2015	Liu J, Wei X Y, Wang Y G, Zhang D D, Wang T M, Lv J H, Gui J, Qu M, Zong Z M. Mild oxidation of Xiaolongtan lignite in aqueous hydrogen peroxide-acetic anhydride. Fuel, 142: 268-273, 2015	英文
2015	Zhao Y P, Tian Y J, Ding M, Dou Y Q, Wei X Y, Fan X, He X F, Zong Z M. Difference in molecular composition of soluble organic species from two Chinese lignites with different geologic ages. Fuel, 148: 120-126, 2015	英文
2015	Li Z K, Wei X Y, Yan H L, Zong Z M. Insight into the structural features of Zhaotong lignite using multiple techniques. Fuel, 153: 176-182, 2015	英文
2015	You C Y, Fan X, Wei X Y, Zheng A L, Zhao Y P, Cao J P, Zhao W, Zhou C C, Zhu J L, Chen L, Wang S Z. Molecular characteristics of a Chinese coal analyzed using mass spectrometry with various ionization modes. Fuel, 155: 122-127, 2015	英文
2015	Kong J, Wei X Y, Yan H L, Li Z K, Zhao M X, Li Y, Zong Z M. Analysis of extractable basic nitrogen compounds in Buliangou subbituminous coal by positive-ion ESI FT-ICR MS. Fuel, 159: 385-391, 2015	英文
2015	马淞江, 刘晓芳, 温和热解条件下内蒙褐煤热解半焦的燃烧性能研究.煤炭学报, 2015年第5期.	その他
2015	马淞江, 刘学鹏, 基于半焦的污泥调质与深度浓缩脱水的实验研究.环境工程学报, 2015年第6期.	その他
2015	戴财胜, 梁丽静, 基于温和热解的低阶煤热解半焦的成浆性能研究.煤炭学报, 2015年第7期.	その他
2015	刘学鹏, 戴财胜, 基于煤粉的污泥调质与机械脱水实验研究.环境科学与技术, (已录用)	その他
2015	戴财胜, 刘晓芳, 低阶煤热解半焦燃烧性能的影响因素研究.煤炭学报(已接收).	その他

2015	戴财胜, 谢凯, 基于半焦的污泥调质与浓缩脱水的影响因素及机理.环境科学学报(已接收).	その他
2015	马淞江, 张仲欢, 半焦与城市污泥混合的燃烧性能研究.环境污染与防治(已录用).	その他
2015	戴财胜,徐欢,基于半焦的污泥调质与机械脱水研究.环境工程学报(已接收).	その他
2015	丁天英, 刘景林, 非热等离子体烃类燃料氧化重整反应器的研究进展.化工学报, 2015, 66(3):872-879	その他
2015	孙鸣,代晓敏,呼伦贝尔褐煤负压热解特性研究.中国矿业大学学报, 2015年5月.	その他
2015	孙鸣, 陈静, 陕北中低温煤焦油重油减压馏分的 GC-MS 分析.化学工程, 2015年9月.	その他
2015	陈静, 孙鸣, 基于苯甲醛交联剂的煤直接液化残渣改性石油沥青.燃料化学学报, 2015年9月.	その他
2015	Caisheng Dai,Songjiang Ma,Xuepeng Liu,Xiaofang Liu,Study on the Pyrolysis Kinetics of Blended Coal in the Fluidized-Bed Reactor.Procedia Engineering 102 ( 2015 ) 1736 – 1741.	英文
2015	Kai Li, Jing-Lin Liu, Xiao-Song Li, Xiao-Bing Zhu, Ai-Min Zhu, Warm plasma catalytic reforming of biogas in a heat-insulated reactor: dramatic energy efficiency and catalyst auto-reduction.Chemical Engineering Journal, 2015, accepted.	英文
2015	Kai Li, Jing-Lin Liu, Xiao-Song Li, Xiao-Bing Zhu, Ai-Min Zhu Post-plasma catalytic oxidative CO2 reforming of methane over Ni-based catalysts.Catalysis Today, 2015, 96: 96-101.	英文
2015	Bin Zhu, Xiao-Song Li, Jing-Lin Liu, Xiaobing Zhu, Ai-Min Zhu,Kinetics study on carbon dioxide reforming of methane in kilohertz spark-discharge plasma.Chemical Engineering Journal, 2015, 264: 445-452.	英文
2015	Liang Zou, Lijun Jin, Xinglong Wang, Haoquan Hu* Pyrolysis of Huolinhe Lignite Extract by In-situ Pyrolysis-Time of Flight Mass Spectrometry.Fuel Processing Technology, 135: 52-59, July 1, 2015.	英文
2015	Lu Li, Hongjun Fani*, Haoquan Hu, A theoretical study on bond dissociation enthalpies of coal based model compounds.Fuel, 2015, 153, 70-77.	英文
2015	Chan Dong, Lijun Jin, Shuaijiang Tao, Yang Li, Haoquan Hu* Xilinguole Lignite Pyrolysis under Methane with or without Ni/Al2O3 as Catalyst.Fuel Processing Technology, 136, 112-117, 2015.	英文
2015	Gang Li, ShiYu Zhang, Lijun Jin, Zichao Tang*, Haoquan Hu*In-situ analysis of volatile products from lignite pyrolysis with pyrolysis-vacuum ultraviolet photoionization and electron impact mass spectrometry.Fuel Processing Technology, 2015, 133, 232-236.	英文

2015	Liang Zou; Lijun Jin; Yang Li; Shengwei Zhu; Haoquan Hu* Effect of tetrahydrofuran extraction on lignite pyrolysis under nitrogen.Journal of Analytical and Applied Pyrolysis, 2015, 112:113-120.	英文
2015	Huiyong Chen , Xiaotong Liu, Xiaoxun MaConfined synthesis of silicalite-1 hollow spheres with a lamellar shell.Scripta Materialia, Volume 95, 15 January 2015, Pages 31–34.	英文
2015	Ming Sun , Xiao-xun Ma, Bo Lv, Xiao-min Dai, Yi Yao, Yuan-yuan Liu, Min He, Xiang-long ZhaoGradient separation of $\geq 300$ °C distillate from low-temperature coal tar based on formaldehyde reactions.Fuel 160 (2015) 16–23.	英文
2015	Ming Sun, Jing Chen, Xiao-min Dai, Xiao-xun Ma, Xiang-long Zhao, Ke Liu, Vacuum distillates and GC-MS analysis of low temperature coal tar from northern shaanxi, coal conversion, 2015, 38 (1) : 58-63	英文
2015	Ming Sun, Jing Chen, Xiao-min Dai, Xiang-long Zhao, Ke Liu , Xiao-xun Ma Controlled separation of low temperature coal tar based on solvent.Fuel Processing Technology 136 (2015) 41–49.	英文
2015	Shui, Hengfu; Hui, Zhen; Jiang, Qingqing; Zhou, Hua; Pan, Chunxiu; Wang, Zhicai; Lei, Zhiping; Ren, Shibiao; Kang, Shigang Study on the use of the thermal dissolution soluble fraction from Shenfu sub-bituminous coal in coke-making coal blends.Energy and Fuels, 29, 3, 1558-1563, 2015.	英文

### 1. 3 その他の著作物(相手側研究チームとの共著のみ)(総説、書籍など)

#### Other Media, e.g. reviews, books (Co-authored with the Partner Research Teams)

年度	全著者名、題目、掲載誌名、巻、号、ページ、発行年	和文／ 英文
2015	Guoqing Guan *, Malinee Kaewpanha, Xiaogang Hao, Abuliti Abudula, Catalytic steam reforming of biomass tar: Prospects and challenges, Renewable & Sustainable Energy Reviews, Vol. 58 pp.450-461,2016	英文

### 1. 4. 1 その他の著作物(相手側研究チームを含まない日本側研究チームの総説、書籍など)

#### Other Media, e.g. reviews, books (by the Japanese Research Teams only, excluding the Partner Research Teams)

年度	全著者名、題目、掲載誌名、巻、号、ページ、発行年	和文／ 英文
なし		

### 1. 4. 2 その他の著作物(日本側研究チームを含まない相手側研究チームの総説、書籍など)

#### Other Media, e.g. reviews, books (by the Partner Research Teams only, excluding the Japanese Research Teams)

年度	全著者名、題目、掲載誌名、巻、号、ページ、発行年	和文／ 英文
2015	XY Wei, ZM Zong, X Fan, ZK Li, Coal-Based Products and Their Uses, In book: Coal production and processing technology, Chapter: 17, Publisher: CRC Press, Editors: M. R. Riazi, Rajender Gupta, pp.383-412	英文

## 2 学会等発表(セミナー、ワークショップ、シンポジウム等)

### Presentations at Academic Conferences etc. (Seminars, Workshops, Symposia)

#### 2.1 学会発表(相手側研究チームと連名の発表)

##### Conference Presentations (Joint Presentations with Partner Research Teams)

年度	言語	発表者、「題目」、学会等名、場所、月日等	招待講演、口頭発表、ポスター発表の別
2013	日本語	Rizkiana Jenny、官国清*、阿布里提、Xiaogang Hao、Zhongde Wang、Wei Huang、堤敦司、石炭/バイオマスの水蒸気共ガス化特性の基礎実験、日本エネルギー学会第22回大会、工学院大学、東京、2013年8月5～6日。	口頭発表 (Oral Presentation)
2013	英語	Y.Ma, C. Shi, Q.Wang, S. Zhang, Guoqing Guan*, Abuliti Abudula, Low-temperature water-gas shift reaction over molybdenum carbide catalyst, 9th World Congress of Chemical Engineering, Coex, Seoul, Korea, Aug.18-23,2013.	ポスター発表 (Poster Session)
2013	英語	Yufei Ma, Guoqing Guan*, Chuan Shi, Aimin Zhu, Xiaogang Hao, Yutaka Kasai, Abuliti Abudula*, Steam reforming of methanol to produce hydrogen over molybdenum carbide-based catalysts at low temperatures, International Symposium on Innovative Materials for Processes in Energy Systems 2013 (IMPRES 2013), in: Innovative Materials for Processes in Energy Systems; B. B., Koyama, M.; Takata, Y., Eds.; Research Publishing Services Fukuoka, Japan, Sept.4-6, 2013:pp45-46.	ポスター発表 (Poster Session)
2014	日本語	Jenny Rizkiana、官国清*、Wahyu Bambang Widayatno、阿布里提、Xiaogang Hao、Xiumin Li、Wei Huang、堤敦司、ゼオライト触媒による石炭・バイオマスの共熱分解、第51回石炭科学会議、仙台、2014年10月22～23日。	口頭発表 (Oral Presentation)
2014	英語	Wahyu B. Widayatno, J. Rizkiana, Guoqing Guan*, X. Hao, S. Ma, Katsuki Kusakabe, Abuliti Abudula, Catalytic deoxygenation and product selectivity properties for bio-oil derived from Fallopija Japonica over USY, ZSM-5, and $\beta$ -zeolite, The 27th International Symposium on Chemical Engineering, Kuala Lumpur Convention Centre, Malaysia, Dec. 5-7, 2014 (CD)	口頭発表 (Oral Presentation)
2014	英語	J. Rizkiana, Guoqing Guan, Xiaogang Hao, Wei Huang, Atsushi Tsutsumi, Abuliti Abudula, Mild Pyrolysis of Low-rank Coal for Oil Production in Molten Salts, 4th Asian Conference on Innovative Energy & Environmental Chemical Engineering, November 9-12, 2014, The Ocean Resort, Yeosu, Korea.	口頭発表 (Oral Presentation)
2015	英語	Rizkiana Jenny、官国清*、阿布里提*、郝曉剛、黃偉、ゼオライト担持金属触媒により石炭・バイオマス共熱分解油のアップグレード、日本化学工学会第80回年会、芝浦工業大学、2015年3月19～21日。	口頭発表 (Oral Presentation)
2015	日本語	Rizkiana Jenny、官国清*、Wahyu Bambang Widayatno、Jingxuan Yang、Xiaogang Hao、阿布里提、126. Properties and catalytic activity of metal loaded zeolite for pyrolytic oil upgrading, 平成27年度化学系学協会東北大会、弘前大学、2015年9月12日～13日	ポスター発表 (Poster Session)
2015	英語	Guoqing Guan*, Jenny Rizkiana, Abuliti Abudula, Xiaogang Hao, Wei Huang, Caisheng Dai, Songjiang Ma, Mild copyrolysis of low rank coal with biomass for enhancing oil production and in-situ catalytic upgrading of the pyrolysis oil, The 3rd Joint Meeting of Strategic Japanese-Chinese Joint Research Program, Shonan Village Center, Kanagawa, Japan, October 26-27, 2015	口頭発表 (Oral Presentation)
2015	日本語	Jenny Rizkiana、官国清*、楊景軒、阿布里提、Xiaogang Hao、Wei Huang、堤敦司、松岡浩一、ゼオライト酸性質の調整による石炭/バイオマス共熱分解油のアップグレード、第52回石炭科学会議、三重県伊勢市観光文化会館、2015年10月28日～29日	口頭発表 (Oral Presentation)

2015	英語	Song-Jiang Ma, Xiaofang Liu, Caisheng Dai, Xuepeng Liu, Lijing Liang, Guoqing Guan, Combustion performance of semi-coke from Inner Mongolia lignite under mild pyrolysis conditions, The 3rd Joint Meeting of Strategic Japanese-Chinese Joint Research Program, Shonan Village Center, Kanagawa, Japan, October 26-27, 2015	ポスター発表 (Poster Session)
2015	英語	Caisheng Dai, Xuepeng Liu, Songjiang Ma, Xiaofang Liu, Lijing Liang, Liangliang Liu, Guoqing Guan, Experimental investigation of sludge conditioning for deep dewatering of sludge by using semi-coke, The 3rd Joint Meeting of Strategic Japanese-Chinese Joint Research Program, Shonan Village Center, Kanagawa, Japan, October 26-27, 2015	ポスター発表 (Poster Session)
2015	英語	Junli Wang, Wenhao Lian, Peng Li, Xiaogang Hao, Wei Huang, Chihiro Fushimi, Atsushi Tsutsumi, Guoqing Guan DAEM model for coal pyrolysis kinetics and modelling of pyrolysis in large coal particles, The 3rd Joint Meeting of Strategic Japanese-Chinese Joint Research Program, Shonan Village Center, Kanagawa, Japan, October 26-27, 2015	ポスター発表 (Poster Session)
2015	英語	Wenhao Lian, Zhonglin Zhang, Xiaogang Hao, Wei Huang, Chihiro Fushimi, Atsushi Tsutsumi, Guoqing Guan, CFD simulation of gas-solid-solid co-current downflow in a downer reactor for coal pyrolysis, The 3rd Joint Meeting of Strategic Japanese-Chinese Joint Research Program, Shonan Village Center, Kanagawa, Japan, October 26-27, 2015	ポスター発表 (Poster Session)
2015	英語	Xiaogang Hao, Junli Wang, Wenhao Lian, Peng Li, Wei Huang, Chihiro Fushimi, Guoqing Guan, Atsushi Tsutsumi, 67. CFD simulation of downer reactor of TBCFB for catalytic depolymerization of low rank coal, The 3rd Joint Meeting of Strategic Japanese-Chinese Joint Research Program, Shonan Village Center, Kanagawa, Japan, October 26-27, 2015	口頭発表 (Oral Presentation)
2015	英語	J. Liu, Q. Zhang, L. Liang, J. Huai, W. Huang, X. Huang, Z. Zhang, X. Hao, Guoqing Guan, 68. Catalytic depolymerization of low-temperature char for producing high-value chemicals over Fe-based catalysts, The 3rd Joint Meeting of Strategic Japanese-Chinese Joint Research Program, Shonan Village Center, Kanagawa, Japan, October 26-27, 2015	口頭発表 (Oral Presentation)
2015	英語	Qian Zhang, Litong Liang, Juntian Huai, Wei Huang, Xiaojuan Huang, Jianwei Liu, Zhonglin Zhang, Xiaogang Hao, Guoqing Guan, Catalytic depolymerization of Yunnan lignite for improving tar yield, The 3rd Joint Meeting of Strategic Japanese-Chinese Joint Research Program, Shonan Village Center, Kanagawa, Japan, October 26-27, 2015	ポスター発表 (Poster Session)

## 2. 2. 1 学会発表(相手側研究チームを含まない日本側研究チームの発表)

### Conference Presentations (by Japanese Research Teams, excluding Partner Research Teams)

年度	言語	発表者、「題目」、学会等名、場所、月日等	招待講演、口頭発表、ポスター発表の別
2013	日本語	堀口 和哉、佐藤 和好、宝田 恭之、“スズ酸バリウム構造がタールの改質活性に及ぼす影響”, 粉体工学会第49回夏期シンポジウム, 2013年7月18日	口頭発表 (Oral Presentation)
2013	日本語	佐藤 星斗、Sirimirin Meesuk、佐藤 和好、宝田 恭之、“天然酸化鉄微粒子を用いたバイオマスの低温熱分解”、粉体工学会第49回夏季シンポジウム、ホテルマウント富士、2013年7月18-19日	口頭発表 (Oral Presentation)
2013	英語	Guoqing Guan*, Development of Advanced Coal/Biomass Gasification Technology and Novel Materials for SOFCs, Frontier in Chemical Engineering- the 5th Global Chinese Chemical Engineering Symposium, Xi'an, China, July 22-25, 2013	招待講演 (Guest/Invited Speaker)
2013	英語	Malinee Kaewpanha, Yufei Ma、官国清*、阿布里提、In-situ supported Mo <sub>2</sub> C on biomass char for tar steam reforming, 日本化学工学会盛岡大会、岩手大学、2013年8月7~8日(奨励賞).	ポスター発表 (Poster Session)
2013	英語	Rizkiana Jenny、官国清、阿布里提、溶融塩中バイオマスのマイルド熱分解特性、日本化学工学会盛岡大会、岩手大学、2013年8月7~8日(奨励賞).	ポスター発表 (Poster Session)
2013	日本語	佐藤 星斗、Sirimirin Meesuk、佐藤 和好、宝田 恭之、“リモナイトを用いたバイオマスの低温熱分解”、第22回日本エネルギー学会大会、工学院大学、2013年8月5-6日	口頭発表 (Oral Presentation)

2013	英語	J.P. Cao, X.Y. Zhao, P. Shi, B.S. Wang, S.S. Huang, X.Y. Wei and Takarada T, "Nitrogen Transformation during Pyrolysis/Gasification of Livestock Compost", 2013 International Conference on Coal Science and Technology, Stage College, PA, USA, Sept.29-Oct.3, 2013	口頭発表 (Oral Presentation)
2013	英語	Keiichi Kaneko, Tomoyuki Hoshino, Kazuyoshi Sato and Takayuki Takarada, "Low temperature gasification of poultry manure using catalyst", 2013 International Conference on Coal Science and Technology, Stage College, PA, USA, Sept.29-Oct.3, 2013	口頭発表 (Oral Presentation)
2013	英語	Koyo Norinaga, Detailed chemical kinetic modeling toward better understanding of complex reactions of multi-component mixtures derived from carbon resources, The 63rd Canadian Chemical Engineering Conference (Frontier in Chemical Engineering Lecture Series, Application of Clean Coal Technology), Fredericton, New Brunswick, Canada, 2013.10.23.	招待講演 (Guest/Invited Speaker)
2013	英語	B.S. Wang, J.P. Cao, X.Y. Zhao and T. Takarada, "Preparation of nickel-loaded brown coal catalysts for catalytic gasification of biomass", The 12th Japan-China Symposium on Coal and C1 Chemistry, Fukuoka, Japan, Oct.28-Nov.1, 2013	口頭発表 (Oral Presentation)
2013	英語	Keiichi Kaneko, Sirimirin Meesuk, Kazuyoshi Sato and Takayuki Takarada, "Low temperature Carbonization and Ashing Process of chicken manure using Ni base and Limonite catalysts", The 12th Japan-China Symposium on Coal and C1 Chemistry, Fukuoka, Japan, Oct.28-Nov.1, 2013	口頭発表 (Oral Presentation)
2013	英語	P. Shi, X. Huang, J.P. Cao, X.Y. Zhao, X.Y. Wei and T. Takarada, "Fast pyrolysis of sewage sludge: effects of temperature and sweeping gas flow rate", The 12th Japan-China Symposium on Coal and C1 Chemistry, Fukuoka, Japan, Oct.28-Nov.1, 2013	口頭発表 (Oral Presentation)
2013	英語	Liuyun Li, Hiroo Kunii, Yohei Ohtake, Masamitsu Yamauchi, Hee-Joon Kim, Tadaaki Shimizu and Takayuki Takarada, "Behaviors of limonite and a calcined dolomite for hydrogen-rich gas production in biomass steam gasification", The 12th Japan-China Symposium on Coal and C1 Chemistry, Fukuoka, Japan, Oct.28-Nov.1, 2013	口頭発表 (Oral Presentation)
2013	英語	Thimthong Narumon, Ryota Tanaka, Kudo Shinji, Hayashi Jun-ichiro, Koyo Norinaga, An Eulerian Multiphase Approach for Simulating Biomass Pyrolysis in Moving-Bed Reactor, 第12回日中石炭・C1化学シンポジウム, 福岡, 2013.10.29.	ポスター発表 (Poster Session)
2013	英語	Huamei Yang, Kudo Shinji, Hayashi Jun-ichiro, Koyo Norinaga, Quantitative Analysis of Products in Secondary Pyrolysis of Lignin toward Detailed Kinetic Modeling, 第12回日中石炭・C1化学シンポジウム, 福岡, 2013.10.29.	ポスター発表 (Poster Session)
2013	英語	Kazuhiro Uemura, Koyo Norinaga, Kudo Shinji, Hayashi Jun-ichiro, Hisahiro Einaga, Experimental Investigation for the Conversion Characteristics of Products from Fast Pyrolysis of Biomass to Aromatic Compounds over Zeolite Catalyst, 第12回日中石炭・C1化学シンポジウム, 福岡, 2013.10.30.	口頭発表 (Oral Presentation)
2013	英語	Koichi Matsuoka, Sou Hosokai, Koji Kuramoto, Hiroaki Sato, Yoshizo Suzuki, Yasumasa Kawabata, Hideki Nakagome, "Control of char-volatile interactions in circulating fluidized bed gasification reactor", 12th Japan-China Symposium on Coal and C1 Chemistry, Fukuoka (2013/10/30)	口頭発表 (Oral Presentation)
2013	英語	*Chihiro Fushimi, Masanori Ishizuka, Guoqing Guan, Yoshizo Suzuki, Koyo Norinaga, Jun-ichiro Hayashi, Atsushi Tsutsumi "Hydrodynamic Behavior of Binary Mixture of Solids in a Triple-Bed Combined Circulating Fluidized Bed" 12th China-Japan Symposium on Coal and C1 Chemistry, Oct. 29-30, 2013, Fukuoka, Japan	口頭発表 (Oral Presentation)
2013	英語	Chihiro Fushimi*, Masanori Ishizuka, Guoqing Guan, Yoshizo Suzuki, Koyo Norinaga, Jun-ichiro Hayashi, Atsushi Tsutsumi Hydrodynamic Behaviors of Sand and Plastic Particles in a Large-Scale Triple Bed Combined Circulating Fluidized Bed" AIChE Annual Meeting 2013, Nov. 3-8, 2013, San Francisco, CA, USA	口頭発表 (Oral Presentation)
2013	英語	Thimthong Narumon, Kudo Shinji, Hayashi Jun-ichiro, Koyo Norinaga, Matthias Kestel, Andreas Richter, Petr A. Nikrityuk, An Application of CFD for Simulating Biomass Pyrolysis in a Moving-Bed Reactor, The 2nd Joint Conference on "Renewable Energy and Nanotechnology", Hiroshima, 2013.11.25.	口頭発表 (Oral Presentation)

2013	日本語	川端康正, 和嶋隆昌, 中込秀樹, 松岡浩一, 細貝聡, 鈴木善三, “循環流動層における石炭熱分解揮発分のチャーによる改質”, 第19回流動化・粒子プロセッシングシンポジウム, (2013/11/28)	口頭発表 (Oral Presentation)
2013	英語	Koichi Matsuoka, Sou Hosokai, Koji Kuramoto, Hiroaki Sato, Yoshizo Suzuki, Yasumasa Kawabata, Hideki Nakagome, “Fate of volatiles during coal gasification in circulating fluidized bed gasification reactor”, International Symposium on Ecotopia Science, Nagoya(2013/12/14)	口頭発表 (Oral Presentation)
2013	英語	Thimthong Narumon, Kudo Shinji, Hayashi Jun-ichiro, Koyo Norinaga, A 3D Numerical Simulation of Biomass Pyrolysis in a Moving-Bed Reactor, The 26th International Symposium on Chemical Engineering, Busan, South Korea, 2013.12.07.	口頭発表 (Oral Presentation)
2013	英語	Kazuhiro Uemura, Kudo Shinji, Hayashi Jun-ichiro, Koyo Norinaga, Experimental investigations for the reaction pathways leading to aromatic hydrocarbons in in-situ reforming of products derived from fast pyrolysis of biomass over zeolite catalysts, The 26th International Symposium on Chemical Engineering, Busan, South Korea, 2013.12.07.	ポスター発表 (Poster Session)
2013	英語	Ryota Tanaka, Kudo Shinji, Hayashi Jun-ichiro, Watanabe, Koyo Norinaga, A CFD Study of Non-Catalytic Partial Oxidation of Coke Oven Gas with Considering Turbulence-Chemistry Interaction, The 26th International Symposium on Chemical Engineering, Busan, South Korea, 2013.12.07.	ポスター発表 (Poster Session)
2013	日本語	則永 行庸, 固体炭素資源熱化学転換反応の理解と予測, 日本エネルギー学会 リサイクル部会・ガス化部会 勉強会, 東京, 2013.12.20.	招待講演 (Guest/Invited Speaker)
2013	英語	Narumon Thimthong, Ryota Tanaka, Kudo Shinji, Hayashi Jun-ichiro, Koyo Norinaga, Detailed chemical kinetic modeling for gas-phase partial oxidation of volatiles derived from rapid pyrolysis of ligno-cellulosic biomass, 1st Asian Conference on Biomass Science, Kochi, 2014.01.14.	口頭発表 (Oral Presentation)
2013	英語	Huamei Yang, Kudo Shinji, Hayashi Jun-ichiro, Koyo Norinaga, Chemical structures and primary pyrolysis characteristics of lignins obtained from different preparation methods, 1st Asian Conference on Biomass Science, Kochi, 2014.01.14.	口頭発表 (Oral Presentation)
2013	英語	Koyo Norinaga, Detailed chemical kinetic modeling as a new approach for understanding complex reactions included in thermochemical conversions of carbon resources. Seminar at School of Chemistry & Chemical Engineering Anhui University of Technology, Prof. Hengfu Shui Research Group (Maanshan, Anhui, China, Mar. 21st 2014)	口頭発表 (Oral Presentation)
2013	英語	Masanori Ishizuka, Yuping Liu, Yasuki Kansha, Atsushi Tsutsumi, Modeling of triple bed circulating fluidized bed coal gasifier flow behavior based on equivalent circuit model, International Conference on Green Energy and Technology, Aug. 24-26, Kitakyushu (2013)	口頭発表 (Oral Presentation)
2013	英語	Masanori Ishizuka, Yuji Yoshie, Yasuki Kansha, Atsushi Tsutsumi, Characteristics of Heat Transfer in Binary-Solid Downflow, The 12th Japan-China Symposium on Coal and C1 Chemistry, 28 Oct.-1 Nov., Fukuoka (2013)	口頭発表 (Oral Presentation)
2013	英語	Masanori Ishizuka, Yuping Liu, Yasuki Kansha, Atsushi Tsutsumi, Modeling of Triple Bed Circulating Fluidized Bed Coal Gasifier Flow Behavior Based on Equivalent Circuit Model, International Conference of Coal Science & Technology 2013 (ICCS&T 2013), 29 Sept.-3 Oct., Pennsylvania (2013)	口頭発表 (Oral Presentation)
2014	英語	Wahyu Bambang Widayatno, Guoqing Guan*, Abuliti Abudula, Promoting properties of Fallopia japonica char on steam reforming of tar, The 1st Asian Conference on Biomass Science, Kochi, Japan, Jan. 14, 2014. (CD)	口頭発表 (Oral Presentation)
2014	日本語	Rizkiana Jenny、官国清*、阿布里提、堤敦司, バイオマス灰を用いた低品質石炭ガス化反応性の向上, 第9回バイオマス科学会議、高知、2014年1月15～16日。	ポスター発表 (Poster Session)
2014	日本語	Kaewpanha Malinee、官国清*、阿布里提, バイオマスチャー担持Mo2Cによるタールの水蒸気改質反応, 第9回バイオマス科学会議、高知、2014年1月15～16日。	ポスター発表 (Poster Session)



2014	日本語	Wahyu Bambang Widayatno、官国清*、阿布里提、金属担持したイタドリチャーを用いたタールの改質、日本化学工学会第79回年会、岐阜大学、2014年3月18～20日。	口頭発表 (Oral Presentation)
2014	日本語	Rizkiana Jenny、官国清、阿布里提、焼成貝殻を用いた低品質石炭の低温ガス化、日本化学工学会第79回年会、岐阜大学、2014年3月18～20日	口頭発表 (Oral Presentation)
2014	日本語	曹景沛、松嶋彩、佐藤和好、宝田恭之、”触媒を用いたバイオマス揮発分の低温改質” 化学工学会 第79年会、岐阜大学柳戸キャンパス、2014年3月18-20日	口頭発表 (Oral Presentation)
2014	日本語	Malinee Kaewpanha、官国清*、阿布里提、Coを担持したドロマイト及び貝殻によるタルの水蒸気改質、日本化学工学会第79回年会、岐阜大学、2014年3月18～20日。	口頭発表 (Oral Presentation)
2014	英語	Koichi Matsuoka, Sou Hosokai, Koji Kuramoto, Yoshizo Suzuki, Yasumasa Kawabata, Takaaki Wajima, Hideki Nakagome, “Low temperature gasification of low-rank coal using a circulating fluidized bed gasifier”, 6th International Freiberg Conference on IGCC & XtL Technologies, Coal Conversion and Syngas, Dresden, Germany, (2014/5/15)	ポスター発表 (Poster Session)
2014	日本語	川端康正、和嶋隆昌、中込秀樹、細貝聡、鈴木善三、松岡浩一、“石炭チャーと揮発分の相互作用を利用したタールの改質”，第19回 動力・エネルギー技術シンポジウム(2014/5/23)	口頭発表 (Oral Presentation)
2014	日本語	宝田恭之、「褐炭を用いた微粒子調整とその応用」、粉体工学会2014年度春季研究発表会、京都、2014年5月29日～30日	口頭発表 (Oral Presentation)
2014	英語	Yufei Ma, Guoqing Guan*, Abuliti Abudula, Steam reforming of methanol on copper modified molybdenum carbide catalysts, The Seventh Tokyo Conference on Advanced Catalytic Science and Technology (TOCAT7), June 1-6, 2014, Kyoto, Japan.	ポスター発表 (Poster Session)
2014	日本語	坂本元、HUANG YONG、工藤真二、則永行庸、林潤一郎、褐炭原料を媒介とする重質油リサイクル式熱分解、第23回日本エネルギー学会大会、福岡、2014.07.19.	ポスター発表 (Poster Session)
2014	英語	Chengyi Li, Kudo Shinji, Hayashi Jun-ichiro, Koyo Norinaga, A numerical study on coal conversion in a drop-tube reactor using CFD coupled with a lumped kinetic model, 第23回日本エネルギー学会大会、福岡、2014.07.20.	口頭発表 (Oral Presentation)
2014	英語	Huamei YANG, Srinivas Appari, Kudo Shinji, Hayashi Jun-ichiro, Koyo Norinaga, Estimations of activation energy and heat of formation for radical addition reactions of monoaromatic compounds based on electronic structure calculation, 第23回日本エネルギー学会大会、福岡、2014.07.20.	口頭発表 (Oral Presentation)
2014	英語	Jing-Pei Cao, Aya Matsushima, Keiichi Kaneko and Takayuki Takarada, "Low-Temperature Catalytic Reforming of Volatile Matter from Biomass Pyrolysis", Grand Renewable Energy 2014, Tokyo 2014.7.29	口頭発表 (Oral Presentation)
2014	日本語	Jenny Rizkiana、官国清*、Wahyu Bambang Widayatno、阿布里提、低品質石炭/バイオマス共熱分解による燃料油の生成特性、第23回日本エネルギー学会年次大会、九州大学、2014年7月19～20日。	口頭発表 (Oral Presentation)
2014	英語	Yasumasa Kawabata, Takaaki Wajima, Hideki Nakagome, Sou Hosokai, Hiroaki Sato, Yoshizo Suzuki, Koichi Matsuoka, “Characteristics of tar emitted during coal pyrolysis under condition for promoting char-volatiles interaction in CFB reactor”, 4th International Symposium on Gasification and Its Application, Vienna,(2014/9/2)	口頭発表 (Oral Presentation)
2014	英語	Narumon Thimthong, Koyo Norinaga, Detailed Chemical Kinetic Modeling of In-Situ Thermal Reforming of Volatiles Derived from Fast Pyrolysis of Lignocellulosic Biomass, ISCRE 23 & APCRE 7, Bangkok, 2014.09.08.	ポスター発表 (Poster Session)
2014	日本語	川端康正、和嶋隆昌、中込秀樹、細貝聡、鈴木善三、松岡浩一、“石炭ガス化過程におけるチャー・揮発分相互作用に及ぼす操作条件の影響”，化学工学会(2014/9/18)	口頭発表 (Oral Presentation)

2014	英語	Shuhei Okuyama, Chihiro Fushimi, The 2nd Joint Meeting of Strategic Japanese-Chinese Joint Research Program September 19-21, 2014, Taiyuan, China	口頭発表 (Oral Presentation)
2014	英語	Koichi Matsuoka, "Low temperature gasification of coal using a circulating fluidized bed gasifier", Seminar at Institute of Process Engineering, Chinese Academy of Sciences, Beijing, China (2014/9/22)	招待講演 (Guest/Invited Speaker)
2014	日本語	小松真太郎, 神成 尚克, 宝田 恭之、「触媒流動層内での触媒担持褐炭の熱分解・ガス化」、第51回石炭科学会議、仙台、2014年10月21日～23日	口頭発表 (Oral Presentation)
2014	日本語	川端康正, 和嶋隆昌, 中込秀樹, 細貝聡, 佐藤浩昭, 鈴木善三, 松岡浩一, "石炭チャー・揮発分相互作用によるタールの低減と組成変化", 第51回石炭科学会議,(2014/10/22)	口頭発表 (Oral Presentation)
2014	英語	ChengyiLi, Kudo Shinji, Hayashi Jun-ichiro, Koyo Norinaga,Effect of particle size and H2O/CO2/O2 partial pressures on gasification rate of nascent char in an atmospheric drop tube reactor, 第51回石炭科学会議, 仙台, 2014.10.22.	口頭発表 (Oral Presentation)
2014	英語	Yasumasa Kawabata, Takaaki Wajima, Hideki Nakagome, Sou Hosokai, Koji Kuramoto, Hiroaki Sato, Yoshizo Suzuki, Koichi Matsuoka, "Utilizing Char-volatiles Interaction to Improve Tar Cracking in Circulating Fluidized Bed Gasification Reactor", The 4th Asian Conference on Innovative Energy & Environmental Chemical Engineering, Yeosu, (2014/11/11)	口頭発表 (Oral Presentation)
2014	英語	Narumon Thimthong, Ryota Tanaka, Srinivas Appari, Kudo Shinji, Hayashi Jun-ichiro, Koyo Norinaga, An Application of CFD for Simulating Biomass Pyrolysis in a Moving-Bed Reactor, ASCON-IEEChE 2014, Yeosu, South Korea, 2014.11.11.	口頭発表 (Oral Presentation)
2014	日本語	Wahyu Bambang Widayatno、Jenny Rizkiana、官国清*、阿布里提、Beta型ゼオライトによるイタトリ由来バイオオイルのアップグレードイ ング、日本化学工学会新潟大会、2014年11月21～23日。(奨励賞)	ポスター発表 (Poster Session)
2014	英語	Guoqing Guan, Malinee Kaewpanha, Jenny Rizkiana, Patchiya Phanthong, Abuliti Abudula, "Application of waste scallop shell as catalyst for tar removal," 4th Asian Conference on Innovative Energy & Environmental Chemical Engineering, November 9-12, 2014, The Ocean Resort, Yeosu, Korea.	口頭発表 (Oral Presentation)
2014	英語	Malinee Kaewpanha, Guoqing Guan* , Yutaka Kasai, Katsuki Kusakabe, Abuliti Abudula, Steam reforming of tar over Cu catalyst supported on calcined scallop shell, The 27th International Symposium on Chemical Engineering, Kuala Lumpur Convention Centre, Malaysia, Dec. 5-7, 2014 (CD)	口頭発表 (Oral Presentation)
2014	英語	Huamei Yang, Kudo Shinji, Hayashi Jun-ichiro, Koyo Norinaga,Experimental and numerical study on secondary gas phase reaction of lignin, 2nd Asian Conference on Biomass Science, Tsukuba, 2015.01.13.	口頭発表 (Oral Presentation)
2014	英語	Narumon Thimthong, Srinivas Appari, Ryota Tanaka, Keita Iwanaga, Kudo Shinji, Hayashi Jun-ichiro, Koyo Norinaga,Numerical study on steam reforming of biomass tar with detailed chemical kinetic model,2nd Asian Conference on Biomass Science, Tsukuba, 2015.01.13.	口頭発表 (Oral Presentation)
2014	英語	Anis Syazwani Shuhaimi, Srinivas Appari, Kudo Shinji, Hayashi Jun-ichiro, Koyo Norinaga,Process simulation on upgrading of oil-derived from pyrolysis of lignocellulosic biomass,2nd Asian Conference on Biomass Science, Tsukuba, 2015.01.13.	ポスター発表 (Poster Session)
2015	英語	Wahyu Bambang Widayatno, Guoqing Guan*, Abuliti Abudula, Effect of NaOH pretreatment on acid properties and catalytic activity of zeolite in catalytic upgrading of biomass-derived oil, The 2nd Asian Conference on Biomass Science, Tsukuba, Japan, Jan. 13, 2015.(CD)	ポスター発表 (Poster Session)
2015	日本語	Wahyu Bambang Widayatno、官国清*、阿布里提、.ゼオライトの酸性質の調整によるバイオマス由来のオイルのアップグレードへの影響、第10回バイオマス科学会議、つくば、2015年1月14～15日。	ポスター発表 (Poster Session)

2014	日本語	上村和大, 工藤 真二, 林 潤一郎, 則永 行庸, バイオマス急速熱分解生成物の接触改質による芳香族化合物への選択的転換, 第10回バイオマス科学会議, つくば, 2015.01.15.	ポスター発表 (Poster Session)
2014	日本語	松岡浩一, “石炭チャーを利用した低温ガス化時のタール低減” 日本学術振興会 石炭・炭素資源利用技術第148委員会第148回研究会 (2015/2/9)	口頭発表 (Oral Presentation)
2015	日本語	官国清*, 阿布里提, 新たな高効率バイオマスガス化技術開発による青森バイオ燃料産業の創出, H26年度第2回弘前大学北日本新エネルギー研究所新エネルギーフォーラム, 青森市, 2015年2月25日	口頭発表 (Oral Presentation)
2015	日本語	Kaewpanha Malinee, 官国清*, 阿布里提*, バイオマスタールの水蒸気改質用触媒として廃棄卵殻の活用, 日本化学工学会第80回年会, 芝浦工業大学, 2015年3月19~21日.	口頭発表 (Oral Presentation)
2015	日本語	○(学)保谷 燎平・(正)伏見 千尋 “ガス精製を導入した次世代型石炭ガス化複合サイクル発電システムの最適化” 第80回化学工学会年会 平成27年3月19-21日 芝浦工業大学(東京)	ポスター発表 (Poster Session)
2015	日本語	(学)谷村 隼・(正)伏見 千尋 “ダウナー型熱分解炉における石炭の水蒸気熱分解反応機構の解析” 第80回化学工学会年会 平成27年3月19-21日 芝浦工業大学(東京)	ポスター発表 (Poster Session)
2015	日本語	(学)奥山 修平・(正)伏見 千尋 “ダウナー型熱分解炉における石炭熱分解反応に対する熱媒体粒子の影響” 第80回化学工学会年会 平成27年3月19-21日 芝浦工業大学(東京)	ポスター発表 (Poster Session)
2015	英語	Qingxin Zheng, Masato Morimoto, Toshimasa Takanohashi, Catalyzed decarboxylation of aromatic acids in subcritical water and its practical application in coal industry, E&E Forum, Tsukuba, 2015/6/25	ポスター発表 (Poster Session)
2015	英語	Qingxin Zheng, Masato Morimoto, Toshimasa Takanohashi, An Efficient Production of Benzene from Benzoic Acid in Subcritical Water Using a Copper (I) Oxide Catalyst , GSC-7 and the 4th JACI/GSC Symposium, 2015/7/8	口頭発表 (Oral Presentation)
2015	日本語	B. Kongsomart, N. Kannari T. Takarada, L. Li, Catalytic CO2 gasification of a brown coal using biomass ash as a catalyst, 日本エネルギー学会第24回大会, 札幌コンベンションセンター, 2015年8月3日	口頭発表 (Oral Presentation)
2015	日本語	Surachai Karnjanakom, 官国清*, Asep Bayu, 阿布里提, Ni/MCM-41触媒を用いたバイオマスタールの低温水蒸気改質, 日本エネルギー学会第24回大会, 北海道(札幌コンベンションセンター), 2015年8月3日~5日.	口頭発表 (Oral Presentation)
2015	英語	松岡浩一, “Low temperature gasification of coal using a circulating fluidized bed gasifier”, 弘前大学エネルギー変換工学部門学術講演会(2015/8/11).	招待講演 (Guest/Invited Speaker)
2015	英語	Huamei Yang, Shinji Kudo, Jun-ichiro Hayashi, and Koyo Norinaga, THERMAL DECOMPOSITIONS OF MODEL COMPOUNDS OF SOLID FUELS: CATECHOL, HYDROQUINONE, AND RESORCINOL. The 13th China-Japan Symposium on Coal and C1 Chemistry, August 31-September 4, 2015 Dunhuang, Gansu, China	ポスター発表 (Poster Session)
2015	英語	Chengyi Li, Srinivas Appari, Shinji Kudo, Jun-ichiro Hayashi, Hiroaki Watanabe, and Koyo Norinaga, A CFD SIMULATION ON THE REACTING TURBULENCE FLOW IN A BENCH-SCALE REFORMER OF COKE OVEN GAS. The 13th China-Japan Symposium on Coal and C1 Chemistry, August 31-September 4, 2015 Dunhuang, Gansu, China	ポスター発表 (Poster Session)
2015	英語	M. Ishizuka, Y. Sakakibara, A. Tsutsumi “Brown Coal Gasification at Low Temperature” The 13th China-Japan Symposium on Coal and C1 Chemistry, Aug. 31-Sep. 4, Dunhuang, Gansu, China (2015)	口頭発表 (Oral Presentation)
2015	英語	Qingxin Zheng, Masato Morimoto, Toshimasa Takanohashi, Hydrothermal Oxidation and Decarboxylation of Brown Coal, The 13th China-Japan Symposium, Dunhuang, 2015/9/1	口頭発表 (Oral Presentation)

2015	英語	Qingxin Zheng, Masato Morimoto, Toshimasa Takanohashi, Molecular Composition Of Extract Obtained By Hydrothermal Extraction Of Brown Coal , The 13th China-Japan Symposium, Dunhuang, 2015/9/1	口頭発表 (Oral Presentation)
2015	英語	L. Li, A. Matsushima, Y. Sekiya, T. Shimizu, N. Kannari, T. Takarada, "LOW-TEMPERATURE GASIFICATION OF BIOMASS VOLATILE USING A NI-LOADING BROWN COAL CHAR AS A CATALYST", The 13th China-Japan Symposium on Coal and C1 Chemistry, Dunhuang, Gansu, China, September 2, 2015	口頭発表 (Oral Presentation)
2015	英語	B. Kongsomart, B. Tsedenbal, S. Komatsu, N. Kannari, T. Takarada, "LOW TEMPERATURE CATALYTIC GASIFICATION OF BROWN COAL USING EMPTY FRUIT BUNCH", The 13th China-Japan Symposium on Coal and C1 Chemistry, Dunhuang, Gansu, China, September 2, 2015	口頭発表 (Oral Presentation)
2015	日本語	松岡浩一, "気固系反応装置を用いた石炭ガス化技術開発動向・展開", 化学工学会 エネルギー部会炭素資源分科会講演会(2015/9/8).	招待講演 (Guest/Invited Speaker)
2015	日本語	古谷優樹、楊華美、工藤真二、林潤一郎、則永行庸、ベンゼンジオール異性体の熱分解機構:実験と理論、化学工学会第47回秋季大会、札幌、2015.9.9(水)~11(金)	ポスター発表 (Poster Session)
2015	日本語	Wahyu Bambang Widayatno、官国清*、Jenny Rizkiana、阿布里提、金属担持β型ゼオライト触媒を用いたバイオオイルのアップグレード、化学工学会 第47回秋季大会、北海道大学、2015年9月9日~11日(ベストポスター賞)	ポスター発表 (Poster Session)
2015	日本語	Wahyu Bambang Widayatno、官国清*、Jenny Rizkiana、阿布里提、Upgrading of bio-oil using Cu loaded β-zeolite catalyst,平成27年度化学系学協会東北大会、弘前大学、2015年9月12日~13日	ポスター発表 (Poster Session)
2015	日本語	Surachai Karnjanakom、官国清*、Asep Bayu、阿布里提、Aromatic hydrocarbon production from catalytic pyrolysis of cedar using metal/γ-Al <sub>2</sub> O <sub>3</sub> (metal = Cu, Fe and Zn), 平成27年度化学系学協会東北大会、弘前大学、2015年9月12日~13日	ポスター発表 (Poster Session)
2015	英語	Surachai Karnjanakom, Guoqing Guan*, Bayu Asep, Abuliti Abudula Upgrading bio-oil derived from catalytic fast pyrolysis of sunflower stalk: A green ultrasonic method to increase bio-oil yield, Biotechnology International Congress (BIC) 2015, BITEC Bang Na, Bangkok, Thailand. September 9-10th , 2015	口頭発表 (Oral Presentation)
2015	日本語	第一原理計算および実験に基づくレゾルシノールの熱分解機構解析、古谷優樹、楊華美、工藤真二、林潤一郎、則永行庸、 第9回分子科学討論会 2015年9月16日(水)~19日(土) 東京工業大学 大岡山キャンパス	ポスター発表 (Poster Session)
2015	英語	M. Ishizuka, Y. Sakakibara, A. Tsutsumi "Reaction Mechanism of Brown Coal Steam Gasification at Low Temperature" The 2015 International Conference on Coal Science and Technology (ICCS&T), Sep. 27-Oct. 1, Melbourne, Australia (2015)	口頭発表 (Oral Presentation)
2015	英語	*Chihiro Fushimi, Shuhei Okuyama, Hayabusa Tanimura, Hisako Fukushima, Koichi Matsuoka, "Pyrolysis of Low-Rank Coal with Heat Carrying Particles in a Downer Reactor" International Conference on Coal Science & Technology 2015 (ICCS&T 2015) September 27-October 1, 2015, Melbourne, Australia	口頭発表 (Oral Presentation)
2015	英語	B. Kongsomart, N. Kannari, S. Komatsu, T. Takarada, L. Li, "Low Temperature Catalytic Gasification of Brown Coal Using Biomass", International Conference on Coal Science & Technology 2015 (ICCS&T 2015), Melbourne, Australia, Melbourne Convention and Exhibition Centre, Sep 28, 2015	口頭発表 (Oral Presentation)
2015	英語	Masato Morimoto, Qingxin Zheng, Hiroaki Sato, Toshimasa Takanohashi, Molecular Composition Of Extract Prepared By Hydrothermal Extraction Of Brown Coal, International Conference on Coal Science and Technology, Melbourne, 2015/9/28	口頭発表 (Oral Presentation)
2015	英語	Qingxin Zheng, Masato Morimoto, Toshimasa Takanohashi, Oxidation And Decarboxylation Of Coal, International Conference on Coal Science and Technology, Melbourne, 2015/9/28	口頭発表 (Oral Presentation)

2015	英語	*Hisako Fukushima, Miho Kobayashi, Shuhei Okuyama, Hayabusa Tanimura, Chihiro Fushimi, Koichi Matsuoka "Pyrolysis of Low-Rank Coal with Heat Carrying Particles in a Downer Reactor" The 3rd Joint Meeting of Strategic Japanese-Chinese Joint Research Program October 26-27, 2015, Hayama, Kanagawa, Japan	ポスター発表 (Poster Session)
2015	英語	*Ryouhei Hoya, Chihiro Fushimi "Development of Advanced Integrated coal Gasification Combined Cycle (A-IGCC) Power Generation Systems with a Gas Treating Unit" The 3rd Joint Meeting of Strategic Japanese-Chinese Joint Research Program October 26-27, 2015, Hayama, Kanagawa, Japan	ポスター発表 (Poster Session)
2015	英語	*Ryouhei HOYA and Chihiro FUSHIMI "Development of Advanced Integrated coal Gasification Combined Cycle (A-IGCC) Power Generation Systems with a Gas Treating Unit" International Conference on Power Engineering-15 (ICOPE-15) November 30-December 4, 2015, Yokohama, Japan	口頭発表 (Oral Presentation)
2015	英語	T. Takarada, N. Kannari, S. Komatsu, "Pyrolysis and steam gasification of metal-loaded brown coals in fluidized bed", The 3rd Joint Meeting of Strategic Japanese-Chinese Joint Research Program, Shonan Village Center, Oct. 26~27, 2015	口頭発表 (Oral Presentation)
2015	英語	Qingxin Zheng, Masato Morimoto, Toshimasa Takanohashi, Hydrothermal Oxidation and Decarboxylation of Brown Coal, The 3rd Joint Meeting of Strategic Japanese-Chinese Joint Research Program, Shonan, 2015/10/27	口頭発表 (Oral Presentation)
2015	英語	Qingxin Zheng, Masato Morimoto, Toshimasa Takanohashi, 褐炭の水熱酸化－水熱脱炭酸プロセス, 第52回石炭科学会議, 伊勢, 2015/10/28	口頭発表 (Oral Presentation)
2015	日本語	○谷村 隼、小林 美穂、福島 寿子、奥山 修平、伏見 千尋(東京農工大学)、松岡 浩一(産総研) "熱媒体粒子を供給した時のダウンナー型反応器での石炭の熱分解反応" 第52回石炭科学会議 平成27年10月28-29日 伊勢市観光文化会館(三重)	口頭発表 (Oral Presentation)
2015	英語	B. Kongsomart, B. Tsedenbal, S. Komatsu, N. Kannari and T. Takarada, "Low temperature catalytic gasification of brown coal by using biomass" 1st SEOULTECH-GU Joint Seminar on Cooperation of Politics and Technology, Gunma University, Jan. 13, 2016	ポスター発表 (Poster Session)
2015	英語	S. Komatsu, N. Kannari and T. Takarada, "Pyrolysis and steam gasification of metal-loaded brown coals in fluidized bed" 1st SEOULTECH-GU Joint Seminar on Cooperation of Politics and Technology, Gunma University, Jan. 13, 2016	ポスター発表 (Poster Session)
2015	日本語	○保谷 燎平, 伏見 千尋(農工大) "ガス精製を考慮した次世代型石炭ガス化複合サイクル発電システムの開発" 第52回石炭科学会議 平成27年10月28-29日 伊勢市観光文化会館(三重)	口頭発表 (Oral Presentation)
2015	英語	Yasumasa Kawabata, Takaaki Wajima, Hideki Nakagome, Sou Hosokai, Koji Kuramoto, Hiroaki Sato, Yoshizo Suzuki, Koichi Matsuoka, "Emission of tar during enhancement of volatile-char interaction in pyrolysis of low rank coal", International Conference on Coal Science and Technology, Melbourne, (2015/11/29)	口頭発表 (Oral Presentation)
2015	日本語	川端康正, 和嶋隆昌, 中込秀樹, 細貝聡, 倉本浩司, 佐藤浩昭, 鈴木善三, 松岡浩一, "揮発分-チャー相互作用強化条件における低品位炭タール低減過程の解析" 第52回石炭科学会議(2015/10/28)	口頭発表 (Oral Presentation)
2015	英語	Surachai Karnjanakom, Asep Bayu, Guoqing Guan*, Abuliti Abudula, Catalytic upgrading of bio-oil derived from fast pyrolysis of sunflower stalk over mesoporous alumina, 3rd Asia Conference on Biomass Science, Toki Messe: Niigata Convention Center, January 19, 2016	ポスター発表 (Poster Session)
2015	日本語	松岡浩一, "石炭ガス化技術開発動向・展開", 北海道エネルギー資源環境講演会(2016/1/19)	招待講演 (Guest/Invited Speaker)
2015	日本語	古谷優樹, 工藤真二, 林潤一郎, 則永行庸, 量子化学計算に基づくバイオマス関連物質の熱分解機構の検討, 第11回バイオマス科学会議, 新潟 朱鷺メッセ, 2016.1.20 (水)	ポスター発表 (Poster Session)

2015	日本語	Surachai Karnjanakom、官国清*、Asep Bayu、阿布里提、 $\beta$ -シクロデキストリン補助含浸法にて調製したCu/MCM-41触媒を用いたバイオオイルのアップグレード、第11回バイオマス科学会議、朱鷺メッセ：新潟コンベンションセンター、2016年1月20-21日	ポスター発表 (Poster Session)
2015	日本語	Widayatno Wahyu、Rizkiana Jenny、官国清*、阿布里提、Performance assessments of Cu/X-modified Beta-zeolite (X = Co, Ni, Fe, Mg, Zn) catalysts prepared by co-impregnation for catalytic deoxygenation of bio-oil、化学工学会第81回年会、関西大学、2016年3月13-15日	口頭発表 (Oral Presentation)
2015	英語	Rizkiana Jenny、楊景軒、官国清*、阿布里提、Reaction mechanism of upgrading bio-oil over magnesium loaded zeolite化学工学会第81回年会、関西大学、2016年3月13-15日	口頭発表 (Oral Presentation)
2015	英語	Karnjanakom Surachai、Bayu Asep、官国清*、阿布里提、In-situ catalytic upgrading of bio-oil using $\beta$ -cyclodextrin-assisting prepared Cu/KIT-6 catalyst、化学工学会第81回年会、関西大学、2016年3月13-15日	口頭発表 (Oral Presentation)
2015	日本語	○小林美穂、谷村隼、福島寿子、伏見千尋*、松岡浩一 “水蒸気と珪砂を供給したダウンナー型熱分解炉における石炭の反応性” 第81回化学工学会年会 平成28年3月13-15日、関西大学(大阪)	ポスター発表 (Poster Session)

## 2. 2. 2 学会発表(日本側研究チームを含まない相手側研究チームの発表)

### Conference Presentations (by Partner Research Teams, excluding Japanese Research Teams)

年度	言語	発表者、「題目」、学会等名、場所、月日等	招待講演、口頭発表、ポスター発表の別
2013	その他	高士秋、周琦、韩江则、董鹏伟、张纯、武荣成、许光文。煤炭热解工艺现状及提高热解油气品质的方法。Frontier in Chemical Engineering-the 5th Global Chinese Chemical Engineers Symposium, GCCES-5, Xi'an, China, July 22-25, 2013	口頭発表 (Oral Presentation)
2013	英語	Chan Dong, Lijun Jin, Peng Zheng, Yang Li, Haoquan Hu*. An Integrated Process of Coal Pyrolysis with Methane Steam Reforming for Improving Tar Yield. Thirtieth Annual International Pittsburgh Coal Conference, September 14-19, 2013, Beijing, China.	口頭発表 (Oral Presentation)
2013	英語	Mingguang Song, Lijun Jin, Chan Dong, Haoquan Hu*. CO2 reforming of CH4 over Ni catalyst prepared from MgAl layered double hydroxide by two-steps method. Thirtieth Annual International Pittsburgh Coal Conference, September 14-19, 2013, Beijing, China	口頭発表 (Oral Presentation)
2013	英語	Chan Dong, Lijun Jin, Yang Li, Peng Zheng, Haoquan Hu*. Integrated Process of Coal Pyrolysis with Methane Steam Reforming for Improving Tar Yield. The International Conference for Coal Science and Technology, September 29–October 3, 2013, Pannsylvania, United State.	口頭発表 (Oral Presentation)
2013	英語	Shiqiu Gao, Qi Zhou, Xufei Xu, Tao Zou, Bingfeng Xi, Guangwen Xu. Multistage fluidized bed pyrolysis for upgrading of low-rank coals. The 7th Sino-US Joint Conference of Chemical Engineering, Beijing, China, Oct. 14-18, 2013	招待講演 (Guest/Invited Speaker)
2013	英語	Chan Dong, Lijun Jin, Shuaijiang Tao, Yang Li, Haoquan Hu*. TG-MS Analysis of Evolved Gases during Xilinguole Pyrolysis under Methane. The 12th Japan-China Symposium on Coal and C1 Chemistry, October 28-November 1, 2013, Fukuoka, Japan.	口頭発表 (Oral Presentation)
2013	英語	Qi Zhou, Tao Zou, Lingpeng Zeng, Liqiang Bai, Shiqiu Gao* and Guangwen Xu. A comparative study on pyrolysis of low-rank coal in multistage and integrated fluidized beds. The 12th Japan-China Symposium on Coal and C1 Chemistry, Fukuoka, Japan, Oct. 28-Nov. 1, 2013	口頭発表 (Oral Presentation)
2013	英語	Jinhui Zhan, Shiqiu Gao, Guangwen Xu. Study on the reaction mechanism of a subbituminous coal pyrolysis by REAXFF molecular dynamics simulation. The 12th Japan-China Symposium on Coal and C1 Chemistry, Fukuoka, Japan, Oct. 28-Nov. 1, 2013	ポスター発表 (Poster Session)
2014	英語	Haoquan Hu. Integrated process of coal pyrolysis with steam reforming of methane for improving tar yield. 2014 Australia-China Symposium on Energy, May 13-15, 2014, Taiyuan, China.	口頭発表 (Oral Presentation)

2014	英語	Chan Dong, Haoquan Hu, Lijun Jin, Integrated Process of Coal Pyrolysis with Steam Reforming of Methane for Improving Tar Yield. 6th international Freiberg Conference on Coal Conversion and Syngas, May 19-22, 2014, Radebeul, Germany.	ポスター発表 (Poster Session)
2014	英語	Chan Dong, Haoquan Hu, Lijun Jin. Integrated Process of Coal Pyrolysis with Steam Reforming of Methane for Improving Tar Yield. 6th international Freiberg Conference on Coal Conversion and Syngas, May 19-22, 2014, Radebeul, Germany.	口頭発表 (Oral Presentation)
2014	英語	Ma Xiaoxun, Zhao Binran, Jin Dujuan, Lian Ke, Chemical Conversion of Carbon Dioxide with Non-Equilibrium Electronegative Ions. The 6th Global Chinese Symposium of Chemical Engineering, HKUST (香港科技大学), July 16-19, 2014	口頭発表 (Oral Presentation)
2014	英語	Zhaohui Chen, Dengguo Lai, Yong Tian, Shiqiu Gao, Guangwen Xu. Coal gasification coupling pyrolysis in an integrated fluidized bed to produce methane-rich syngas. The 10th Korea-China Clean Energy Workshop, Seoul, Korea, Aug. 31-Sep. 3, 2014	口頭発表 (Oral Presentation)
2014	英語	Zhaohui Chen, Qi Zhou, Liqiang Bai, Shiqiu Gao, Guangwen Xu. Production of methane-rich syngas in an integrated fluidized bed by coupling pyrolysis and gasification of low-rank coals. The 4th International Symposium on Gasification and its Application (iSGA-4), Vienna, Austria, Sep. 2-5, 2014	口頭発表 (Oral Presentation)
2014	その他	马晓迅、低变质煤的高效清洁转化利用、天津化学化工协同创新中心: 能源高效清洁利用高级研讨会, 天津, 2014年9月13日	口頭発表 (Oral Presentation)
2014	その他	黄伟, 煤炭资源的可持续开发利用, 挑战与机遇. 第五届能源博览会2014低碳发展高峰论坛, 太原, 2014年9月16-17日	招待講演 (Guest/Invited Speaker)
2014	その他	许光文, 突破煤低温热解技术 推动煤炭分质利用. 第五届能源博览会2014低碳发展高峰论坛, 太原, 2014年9月16-17日.	招待講演 (Guest/Invited Speaker)
2014	その他	马晓迅, 中国能源生产、消费与环境. 中国石油和化工勘察设计协会化学工程设计专业委员会2014年年会暨技术交流会, 西安, 2014年9月21-22日	口頭発表 (Oral Presentation)
2014	英語	Chan Dong, Lijun Jin, Yang Li, Zheng Fu, Haoquan Hu, Integrated Process of Coal Pyrolysis with Methane Steam Reforming: the Influence of Pyrolysis Condition. 31st Annual International Pittsburgh Coal Conference, Oct. 6-9, 2014, Pittsburgh, PA USA.	ポスター発表 (Poster Session)
2014	英語	Chan Dong, Lijun Jin, Yang Li, Zheng Fu, Haoquan Hu. Integrated Process of Coal Pyrolysis with Methane Steam Reforming: the Influence of Pyrolysis Condition. 31st Annual International Pittsburgh Coal Conference, Oct. 6-9, 2014, Pittsburgh, PA USA	ポスター発表 (Poster Session)
2014	英語	Wei X Y, Molecular coal chemistry and fine coal chemical technology. International Workshop on Clean Technologies of Coal and Biomass Utilization. December 3, 2014, Anshan, China	口頭発表 (Oral Presentation)
2014	その他	黄伟, 低阶煤催化解聚. 2014 煤炭清洁转化产业战略研讨会, 内蒙古, 2014年12月20-21日.	口頭発表 (Oral Presentation)
2014	英語	Zhu J L, Fan X, Wang S Z, Wei X Y, Zhao Y P, Cao J P, Zhao Wei, Zong Z M, You C Y, Chen L, Two mass spectrometers for the analysis of high-temperature coal tar. The 249th ACS National Meeting and Exposition, March 22-26, 2015, Denver, USA	口頭発表 (Oral Presentation)
2014	英語	You C Y, Fan X, Zheng A L, Wei X Y, Zhao Y P, Cao J P, Zhao W, Zong Z M, Zhu J L, Chen L, Molecular characteristics of a Chinese subbituminous coal using HPLC/MS. The 249th ACS National Meeting and Exposition, March 22-26, 2015, Denver, USA	口頭発表 (Oral Presentation)
2014	英語	Li X, Zong Z M, Ma W W, Wei X Y, Catalytic hydro-liquefaction of sawdust into high-value small-molecular chemicals over a novel magnetic solid super-base catalyst. The 249th ACS National Meeting and Exposition, March 22-26, 2015, Denver, USA.	口頭発表 (Oral Presentation)

2014	英語	Li S, Wei X Y, Wang T M, Liu C, Lv J H, Zong Z M, Sequential thermal dissolution of extraction residue from Zaozhuang bituminous coal.The 249th ACS National Meeting and Exposition, March 22-26, 2015, Denver, USA.	ポスター発表 (Poster Session)
2014	英語	Yan H L, Zong Z M, Li Z K, Wei X Y, POPLAE liquefaction in water-methanol co-solvent.The 249th ACS National Meeting and Exposition, March 22-26, 2015, Denver, USA	口頭発表 (Oral Presentation)
2014	英語	Zhao W, Fang J J, Zhao C, Lei Q, Zhou K X, Ren Y P, Zhao J, Zong Z M, Wei X Y,Catalytic ethanolysis of wheat stalk over coal cinder.The 249th ACS National Meeting and Exposition,March 22-26, 2015, Denver, USA	口頭発表 (Oral Presentation)
2014	英語	Zhao C, Zhao W, Zhou K X, Fang J J, Ren Y P, Zhao J, Lei Q, Zong Z M, Wei X Y,Catalyzed-cleavage of the bridged bond of coal model compounds over magnetic solid acid.The 249th ACS National Meeting and Exposition,March 22-26, 2015, Denver, USA	ポスター発表 (Poster Session)
2014	英語	Zhao J, Zhao W, Lei Q, Ren Y P, Zhao C, Zhou K X, Fang J J, Zong Z M, Wei X Y,Emulsification and performance measurement of pyrolysis oil/diesel.The 249th ACS National Meeting and Exposition, March 22-26, 2015, Denver, USA	口頭発表 (Oral Presentation)
2014	英語	Tian Y J, Zhao Y P, Chen S, Fan X, Zong Z M, Wei X Y, Co-liquefaction of Shenmu bituminous and white pine sawdust in sub- and supercritical ethanol.The 249th ACS National Meeting and Exposition, March 22-26, 2015, Denver, USA	口頭発表 (Oral Presentation)
2014	英語	Cao J P, Song C, Zhao X Y, Wei X Y, Low-temperature catalytic reforming of volatiles from biomass pyrolysis.The 249th ACS National Meeting & Exposition, March 22-26, 2015, Denver, CO, USA	口頭発表 (Oral Presentation)
2014	英語	Huang X, Cao J P, Zhao X Y, Wei X Y,Optimum conditions to produce triacetone from fast pyrolysis of sewage sludge.The 249th ACS National Meeting & Exposition,March 22-26, 2015, Denver, CO, USA	口頭発表 (Oral Presentation)
2014	英語	Feng X B, Zhao X Y, Cao J P, Wei X Y, Organic oxygen transformation during pyrolysis of Baiyinghua lignite.The 249th ACS National Meeting & Exposition,March 22-26, 2015, Denver, CO, USA	口頭発表 (Oral Presentation)
2014	英語	Huang S S, Zhao X Y, Cao J P, Wei X Y, Nickel oxide/activated carbon composite electrodes for electrochemical capacitors.The 249th ACS National Meeting & Exposition, March 22-26, 2015, Denver, CO, USA	口頭発表 (Oral Presentation)
2015	その他	魏贤勇,精细煤化工—煤化工产业的必然发展趋势.第14届中国煤化工产业大会, 2015年4月15-18日, 南京	ポスター発表 (Poster Session)
2015	その他	魏贤勇,煤转化研究的创新性思维.第二届全国煤化工青年学者论坛,2015年4月25-27日, 马鞍山	口頭発表 (Oral Presentation)
2015	その他	樊星, 魏贤勇,原位电离在煤分子表征中的应用.第二届全国煤化工青年学者论坛, 2015年4月25-27日, 马鞍山	ポスター発表 (Poster Session)
2015	その他	曹景沛,褐煤负载镍催化剂的制备及对焦油裂解的催化作用.第二届全国煤化工青年学者论坛, 2015年4月25-27日, 马鞍山	ポスター発表 (Poster Session)
2015	英語	Ming Sun, Bo Lv, Xiaoxun Ma, Study on Catalytic Pyrolysis of Swelling Shendong Coal.The 7th International conference on mining science and technology, China, Xuzhou, 2015.4.26-4.29	口頭発表 (Oral Presentation)
2015	その他	魏贤勇,煤和农作物秸秆的催化加氢转化.第七届全球华人化工学者论坛, 2015年7月12-15日, 天津	ポスター発表 (Poster Session)
2015	その他	樊星,胜利褐煤热溶转化的组学表征.第七届全球华人化工学者论坛, 2015年7月12-15日, 天津	ポスター発表 (Poster Session)



2015	英語	Wei X Y,Catalysis in molecular coal chemistry.August 9-13, 2015, Busan, Korea	口頭発表 (Oral Presentation)
2015	英語	Ming Sun, Xiao-Xun Ma*,Gradient extraction of the high temperature distillation fraction from low temperature coal tar based on benzaldehyde reactions, Preparation, Pyrolysis, Liquefaction.The 13th Japan China Symposium on Coal and C1 Chemistry, China, Dunhuang, 2015.8.31-9.3	口頭発表 (Oral Presentation)
2015	英語	Chan Dong, Lijun Jin, Yang Li, Yang Zhou and Haoquan Hu*,MECHANISM OF INTEGRATED PEOCESS OF COAL PYROLYSIS WITH STEAM REFORMING OF METHANE BY ISOTOPIC TRACER METHOD.13th China-Japan Symposium on Coal and C1 Chemistry, Dunwang, China, Aug. 31-Sep. 2, 2015.	ポスター発表 (Poster Session)
2015	英語	Yang Zhou,Gang Li, Chan Dong,Yang Li,Lijun Jin and Haoquan Hu*, PYROLYTIC TOF-MS FOR IN SITU CHEMICAL ANALYSIS OF VOLATILE PRODUCTS FROM LIGNITE PYROLYSIS.13th China-Japan Symposium on Coal and C1 Chemistry, Dunwang, China, Aug. 31-Sep. 2, 2015 .	口頭発表 (Oral Presentation)
2015	英語	Haoquan Hu,BOND DISSOCIATION AND STABILIZATION IN COAL PYROLYSIS.13th China-Japan Symposium on Coal and C1 Chemistry, Dunwang, China, Aug. 31-Sep. 2, 2015.	ポスター発表 (Poster Session)
2015	英語	Zhaohui Chen, Dengguo Lai, Yong Shi, Shiqiu Gao, Guangwen Xu, Coal pyrolysis in a transport bed under conditions relevant to the integrated fluidized bed process.The 13th China-Japan Symposium on Coal and C1 Chemistry, Dunhuang, China, Aug. 31-Sep. 3, 2015.	ポスター発表 (Poster Session)
2015	英語	Yong Shi, Dengguo Lai, Zhaohui Chen, Shiqiu Gao, Guangwen Xu,Co-pyrolysis characteristics of coal with oil shale.The 13th China-Japan Symposium on Coal and C1 Chemistry, Dunhuang, China, Aug. 31-Sep. 3, 2015.	口頭発表 (Oral Presentation)
2015	英語	Hengfu Shui, Xinxin Zhang, Lei Yang, Chunxiu Pan, Study on the co-thermal dissolution of Shenfu coal and lignin.The 13th Japan-China Symposium on Coal and C1 Chemistry, Dunhuang, Gansu, China, Aug. 31 ~ Sep. 4, 2015.	ポスター発表 (Poster Session)
2015	英語	Wei X Y, Shui H F,Catalytic hydrogenation of ligh fraction in coal tar.The 2nd Joint Meeting of Strategic Japanese-Chinese Joint Research Program. September 19-21, 2015, Taiyuan	口頭発表 (Oral Presentation)
2015	英語	Zhaohui Chen, Dengguo Lai, Yong Shi, Shiqiu Gao*, Guangwen Xu, Coal pyrolysis in a transport bed integrated to a fluidized bed bottom for char gasification.2015 International Conference on Coal Science & Technology Incorporating 2015 Australia-China Symposium on Energy (2015 ACCS&T/ACSE), Melbourne, Australia, Sep. 27-Oct. 1, 2015.	口頭発表 (Oral Presentation)
2015	英語	Hua Zhou, Lei Yang Hengfu Shui, Chunxiu Pan, Zhicai Wang, Zhiping Lei, Shibiao Ren and Shigang Kang, Thermal plasticity and coking property of thermal dissolution soluble fraction from a sub-bituminous coal.15th International Conference on Coal Science & Technology, Melbourne, Australia, Sep. 27- Oct.1,2015	口頭発表 (Oral Presentation)
2015	英語	Haoquan Hu*, Qiumin Zhang, Lijun Jin, Yang Li,Recent research on coal pyrolysis in DUT.The 8th Sino-USJoint Conference of Chemical Engineering, Shanghai, China, Oct. 12-16, 2015.	招待講演 (Guest/Invited Speaker)
2015	英語	Haoquan Hu, Aimin Zhu,Coal pyrolysis with reforming of methane-rich gas.The 3rd Joint Meeting of Strategic Japanese-Chinese Joint Research Program, Shonan Village Center, Kanagawa, Japan, Oct. 26-27, 2015.	ポスター発表 (Poster Session)
2015	英語	Fang He Hengfu Shui* Hua Zhou Ye Wu Chunxiu Pan Zhicai Wang Zhiping Lei Shibiao Ren and Shigang Kang,Thermolysis of biomass-related model compounds and its promotion on the thermal dissolution of coal.15th International Conference on Coal Science & Technology, Melbourne, Australia, Sep. 27- Oct.1,2015	口頭発表 (Oral Presentation)
2015	英語	Cao J P, Huang X, Wang B S, Song C, Zhao X Y, Wei X Y, Takarada T, Preparation of nickel-loaded resin catalysts for catalytic gasification of corn cob.Abstracts of the 13th China-Japan Symposium on Coal and C1 Chemistry, (OB-24), August 31-September 3, 2015, Dunhuang, China, P. 23	ポスター発表 (Poster Session)

2015	英語	Yan H L, Zong Z M, Li Z K, Wei X Y.Characterization of bio-oils from the alkanolyses of sweet sorghum stalk by negative-ion electrospray ionization Fourier transform ion cyclotron resonance mass spectrometry.Abstracts of the 13th China-Japan Symposium on Coal and C1 Chemistry, (OB-33), August 31-September 3, 2015, Dunhuang, China, pp. 24-25	ポスター発表 (Poster Session)
2015	英語	Huang X, Cao J P, Wang J X, Zhao X Y, Wei X Y, Catalytic fast pyrolysis of sewage sludge in a drop type pyrolyzer for bio-oil production.Abstracts of the 13th China-Japan Symposium on Coal and C1 Chemistry, (OB-36), August 31-September 3, 2015, Dunhuang, China, P. 25	ポスター発表 (Poster Session)
2015	英語	Kong J, Wei X Y, Zong Z M, Identification of nitrogen/oxygen-containing compounds in the extraction residue from Buliangou subbituminous by FT-ICR MS.Abstracts of the 13th China-Japan Symposium on Coal and C1 Chemistry, (OC-3), August 31-September 3, 2015, Dunhuang, China, P. 26	ポスター発表 (Poster Session)
2015	英語	Zhao M X, Wei X Y, Qu M, Zong Z M, A highly active solide superacide catalyst for cracking Car-Calk bond in di(1-naphthyl)methane.Abstracts of the 13th China-Japan Symposium on Coal and C1 Chemistry, (OC-9), August 31-September 3, 2015, Dunhuang, China, P. 27	ポスター発表 (Poster Session)
2015	英語	Tian Y J, Xiao J, Zhao Y P, Ding M, Wei X Y, Extraction and thermal dissolution of two Chinese lignites in binary solvents.Abstracts of the 13th China-Japan Symposium on Coal and C1 Chemistry, (OC-31), August 31-September 3, 2015, Dunhuang, China, P. 30	ポスター発表 (Poster Session)
2015	英語	Li Z K, Wei X Y, Yan H L, Zong Z M,Characterization of products from thermal dissolution of Zhaotong lignite in cyclohexane and methanol by GC/MS and negative-ion ESI FT-ICR MS.Abstracts of the 13th China-Japan Symposium on Coal and C1 Chemistry, (OC-36), August 31-September 3, 2015, Dunhuang, China, P. 31	ポスター発表 (Poster Session)
2015	英語	He S, Cao J P, Huang S S, Zhao X Y, Wei X Y, Preparation of activated carbon from lignite for electric double-layer capacitors.Abstracts of the 13th China-Japan Symposium on Coal and C1 Chemistry, (P-63), August 31-September 3, 2015, Dunhuang, China, P. 41	ポスター発表 (Poster Session)
2015	英語	Li Z K, Wei X Y, Yan H L, Yu Xin Yue, Zong Z M, Thermal dissolution of Zhaotong lignite and characterization of the resulting soluble portions.15th International Conference on Coal Science & Technology/Australia-China Symposium on Energy, September 27-October 1, 2015, Melbourne, Australia .Paper no. 3127282	口頭発表 (Oral Presentation)
2015	英語	Cong X S, Li M, Yu X, Zhang B Y, Ren C G, Zong Z M, Wei X Y, Identification of hopanols from phenol-thermally soluble extract of Shengli lignite.15th International Conference on Coal Science & Technology/Australia-China Symposium on Energy, September 27-October 1, 2015, Melbourne, Australia .Paper no. 3127346	口頭発表 (Oral Presentation)
2015	英語	Fan X, Chen L, Zhou C C, Zhu J L, Zhu T G, Wei X Y,Organic fluoride and distribution of organic species in anthracite with high content of fluorine.15th International Conference on Coal Science & Technology/Australia-China Symposium on Energy, September 27-October 1, 2015, Melbourne, Australia.Paper no. 3134864	口頭発表 (Oral Presentation)
2015	英語	Furutani Y, Kudo S, Hayashi J-I, Wei X Y, Shui H F, Norinaga K,Pyrolysis pathways of dihydroxybenzene isomers: an experimental and theoretical approach.The 3rd Joint Meeting of Strategic Japanese-Chinese Joint Research. October 26-27, 2015, Shonan Village Center, Japan	口頭発表 (Oral Presentation)
2015	その他	魏贤勇,精细煤化工的发展前景.第四届国际清洁能源论坛煤化工产业发展分论坛. 2015年12月16和17日, 澳门金沙城中心	口頭発表 (Oral Presentation)
2015	その他	樊星,煤及其衍生物分子的质谱表征.第四届国际清洁能源论坛煤化工产业发展分论坛. 2015年12月16和17日, 澳门金沙城中心	口頭発表 (Oral Presentation)

### 3 ワークショップ・セミナー・シンポジウム等の開催 Workshops, Seminars, Symposia and Other Events

#### 3. 1. ワークショップ・セミナー・シンポジウム(日本側研究チームおよび/または相手側研究チーム主催) Workshops, Seminars, Symposia (Organized by the Japanese and/or Partner Research Teams)

年度	開催期間	主催者名	名称	場所(国名、都市名、会場名)	参加人数 (チームメンバー 含む)	概要
2013	2013年4月11日	東京大学	日本側キックオフ ミーティング	東京大学生産技術研究所	11	全ての日本側の共同研究参加メンバーが、4月11日に東京大学生産技術研究所に集い、各メンバーの研究内容の打ち合わせと研究計画の確認を行った。
2013	2013年10月28日	福岡	日中参加グループ第一回 研究交流会	福岡リーセントホテル 芙蓉 の間	45	第一回研究交流会を開催した。各グループの研究進展について報告した。今後の研究計画を深く議論した。
2014	2014年9月19日	太原理工大学	日中参加グループ第二回 研究交流会	太原理工大学	68	第二回研究交流会を開催した。各グループの研究進展について報告した。今後の研究計画を深く議論した。
2014	2015年2月5日～ 2015年2月6日	弘前大学北日本 新エネルギー 研究所	中国科学院過程工程研究 所の許光文教授 弘前大学ご訪問	弘前大学	19	石炭熱分解・ガス化技術の基礎研究及び実用化技術についての研究交流講演会を行った。

## 4 研究交流の実績

### Record of Research Exchanges

#### 4.1 日本側から相手国機関への訪問等の実績

##### Record of Visits by the Japanese Side to Partner Institutions

##### 4.1.1 【日本→海外】（日本側研究チームメンバーのみ）

##### (Japan→Overseas) Only those by Japanese Research Team Members

年度	出発日	帰国日	氏名	所属機関	役職	用務先(国名、都市名、研究機関名等)	用務の内容	出張日数
2013	2013/7/22	2013/7/25	官国清	弘前大学	准教授	中国西北大学	官国清准教授は西安で学会を参加した際に、西北大学の馬曉迅教授の研究室を訪問し、石炭のガス化について深く意見交換を行った。また、西安で、中国科学院の高士秋教授、中国鉱業大学の魏賢勇教授、安徽工業大学の水恒福教授、太原理工大学の黄偉教授と共同研究について意見交換した。	4
2013	2014/3/20	2014/3/22	則永行庸	九州大学先導物質化学研究所	准教授	中国、School of Chemistry & Chemical Engineering, 馬鞍山市, 安徽工業大学	石炭等低品位燃料の転換技術に関する研究打ち合わせ	3
2013	2014/3/21	2014/3/21	則永行庸	九州大学	准教授	安徽工業大学	共同研究の打ち合わせ、共同研究	1
2014	2014/5/17	2014/5/18	堤敦司	東京大学	教授	太原理工大学	共同研究の打ち合わせ、共同研究	2
2014	2014/5/23	2014/5/23	堤敦司	東京大学	教授	中国科学院過程工程研究所	共同研究の打ち合わせ、共同研究	1
2014	2014/9/19	2014/9/22	松岡浩一	産業技術総合研究所	グループ長	中国, 北京, 中国科学院	研究施設見学, 意見交換	4
2014	2014/9/19	2014/9/22	鈴木善三	産業技術総合研究所	上級主任研究員	中国, 北京, 中国科学院	研究施設見学, 意見交換	4
2014	2014/9/20	2014/9/20	官国清	弘前大学	准教授	太原理工大学	日本側の学生3人と中国側若手研究者及び院生30人は石炭の研究についての研究を深く議論した。	1
2014	2014/9/21	2014/9/22	官国清	弘前大学	准教授	中国科学院過程工程研究所	産総研の鈴木様、松岡様と一緒に石炭の研究についての講演会及び討論会を行った。	2
2015	2015/7/10	2015/7/12	官国清	弘前大学	准教授	太原理工大学	共同研究の打ち合わせ、中国側の研究進展の確認、共同研究	3
2015	2015/7/15	2015/7/15	官国清	弘前大学	准教授	中国科学院過程工程研究所	共同研究の打ち合わせ	1

4. 1. 2 【日本→海外】（日本側研究チームメンバー以外）

(Japan→Overseas) (Excluding those by Japanese Research Team Memebers)

年度	出発日	帰国日	氏名	所属機関	役職	用務先(国名、都市名、研究機関名等)	用務の内容	出張日数
なし								1

4. 2 相手国側から日本側への訪問等の実績

Record of Visits by Partner Reserach Teams to Japan

4. 2. 1 【海外→日本】（相手側研究チームメンバーのみ）

(Overseas→Japan) Only those by Partner Research Team Members

年度	出発日	帰国日	氏名	所属機関	役職	用務先(国名、都市名、研究機関名等)	用務の内容	出張日数
2013	2013/6/7	2013/6/7	黄偉	太原理工大学	教授	東京、東京大学	中国側の研究代表の太原理工大・黄偉教授(他2名)が来校し、日本側研究代表の東京大学・堤教授(他6名)と研究内容の打ち合わせおよび研究計画の確認を行った。その結果、日中の研究グループを3つのタスクに分け、各タスクの中で、日本と中国のグループのペアリングを行い、今後、各対応グループ間で積極的に交流を進め、共同研究を行っていくこととした。また、全体交流シンポを毎年行っていくことを決め、本年度は、12回日中石炭・C1化学シンポジウムに合わせて、10月28日に福岡で第一回研究交流会を開催することを決定した。	1
2013	2013/6/8	2013/6/11	黄偉	太原理工大学	教授	青森・弘前大学北日本新エネルギー研究所	太原理工大学黄偉教授、郝曉剛教授が弘前大学官研究室に来訪した。弘前大学北日本新エネルギーと「研究教育協力に関する協定」を締結した。また、官研究室のメンバーと石炭・バイオマスガス化や熱分解などについての研究交流も行った。	4
2013	2013/11/2	2013/11/2	Xianyong Wei	中国鉱業大学	教授	福岡・九州大学先導物質化学研究所	共同研究の打ち合わせ	1
2013	2013/11/2	2013/11/2	高士秋	中国科学院過程研究所	研究員	東京大学生産技術研究所堤研訪問	共同研究の打ち合わせ	1
2014	2014/10/1	2014/10/1	Shichao Qi	中国鉱業大学	修士	九州大学	博士後期課程学生入学	1
2015	2015/6/14	2015/6/18	Xiaogang Hao	太原理工大学	教授	青森・弘前大学北日本新エネルギー研究所	共同研究に関する打合せ、共同研究、研究交流講演会を行いました。	5
2015	2015/10/30	2015/10/30	Xianyong Wei	中国鉱業大学	教授	富山・富山大学	共同研究の打ち合わせ	1

2015	2016/1/23	2016/1/23	黄偉	太原理工大学	教授	富山・富山大学	共同研究の打ち合わせ	1
------	-----------	-----------	----	--------	----	---------	------------	---

4. 2. 2 【海外→日本】（相手側研究チームメンバー以外）  
(Overseas→Japan) (Excluding those by Partner Research Team Members)

年度	出発日	帰国日	氏名	所属機関	役職	用務先(国名、都市名、研究機関名等)	用務の内容	出張日数
2014	2014/9/28	2015/9/27	Xiao Du	太原理工大学	博士課程後期学生	弘前大学北日本新エネルギー研究所	共同研究	365
2014	2015/2/5	2015/2/6	Guangwen Xu	中国科学院過程工程研究所	教授	弘前大学北日本新エネルギー研究所	石炭熱分解・ガス化技術の基礎研究及び実用化技術についての研究交流講演会を行った。	2
2015	2015/4/1	2016/3/31	Ruilun Xie	中国鉱業大学	博士課程後期学生	九州大学先端物質化学研究所	共同研究	366
2015	2015/4/1	2016/3/31	Zhanku Li	中国鉱業大学	博士課程後期学生	九州大学先端物質化学研究所	共同研究	366
2015	2015/5/5	2016/2/28	Chunhui Luan	太原理工大学	准教授	富山大学工学部	共同研究	300
2015	2015/5/8	2016/3/31	Xuli Ma	太原理工大学	准教授	弘前大学北日本新エネルギー研究所	共同研究	329
2015	2015/6/14	2015/12/28	Jingxuan Yang	太原理工大学	講師	弘前大学北日本新エネルギー研究所	共同研究	198

## 5 特許出願 Patent Applications

### 5.1. 日本側の単独出願 Independent Applications by Japanese Research Teams

出願年度	出願番号	発明の名称	出願日	出願人	公開番号	発明者	出願国
2014	特願2014-185016	安息香酸からベンゼンを製造する方法	2014/9/11	産業技術総合研究所		森本正人、Zheng Qingxin、鷹觜利公	日本
2014	特願2015-018475	ベンゼン又はナフタレンを製造する方法	2015/2/2	産業技術総合研究所		森本正人、Zheng Qingxin、鷹觜利公	日本

### 5.2. "相手国"側の単独出願 Independent Applications by Partner Countries

出願年度	出願番号	発明の名称	出願日	出願人	公開番号	発明者	出願国
2013	AU 2011325794	Apparatus and method for multistage hierachical pyrolysis and gasification of solid fuels	2013/4/19	中科院过程工程研究所		Shiqiu Gao, Guangwen Xu, Qi Zhou, Xufei Xu, Yin Wang, Qang Li.	その他の国
2013	201310142076	一种芳烃加氢催化剂	2013.04.23	安徽工业大学	CN103191745A	任世彪, 文宏志, 水恒福, 雷智平, 王知彩	"相手国"
2013	13/881,824	Apparatus and method for multistage hierachical pyrolysis and gasification of solid fuels	2013/4/26	中科院过程工程研究所	US 2013/0239479	Shiqiu Gao, Guangwen Xu, Qi Zhou, Xufei Xu, Yin Wang, Qang Li.	その他の国
2013	201310226753.X	一种提高高温煤焦油附加值利用的方法	2013.06.08	安徽工业大学	CN103254928A	水恒福, 任世彪, 曹先中, 雷智平, 王知彩	"相手国"
2013	2013102463573	一种溶剂萃取-柱层析分离煤焦油的方法及装置	2013/6/21	西北大学	CN 103289717 A	孙鸣, 马晓迅, 徐龙	"相手国"
2013	2013102715606	一种中低温煤焦油制备脱酚油和酚醛树脂的方法	2013/7/2	西北大学	CN 103289718 A	孙鸣, 马晓迅, 徐龙	"相手国"
2013	201310331246	合成完全晶化纳米粉体的大气压滑弧放电等离子体反应器	2013/7/31	大连理工大学		朱爱民, 李小松, 朱晓兵, 刘景林	"相手国"
2013	201310346633	碳氢原料固体热载体干馏反应器及干馏方法	2013/8/9	中科院过程工程研究所		许光文, 武荣成, 高士秋, 张纯, 董鹏伟, 韩江则	"相手国"

2013	2013105860993	一种煤直接加氢液化的甲醇混合溶剂前处理方法	2013/11/19	安徽工业大学	ZL201310586099.3	王知彩, 吴德清, 水恒福, 雷智平, 任世彪, 潘春秀, 余传军.	"相手国"
2013	2013106506563	一种污泥脱水调理剂及其深度脱水方法	2013/12/3	湖南科技大学		戴财胜, 马淞江, 刘良良, 梁丽静, 刘晓芳, 刘学鹏	"相手国"
2013	2013106512672	一种复合型水煤浆或水焦浆添加剂及其制备方法和应用	2013/12/3	湖南科技大学		戴财胜, 马淞江	"相手国"
2013	2013106506563	一种污泥脱水调理剂及其深度脱水方法	2013/12/3	湖南科技大学		戴财胜, 马淞江, 刘良良, 梁丽静, 刘晓芳, 刘学鹏	その他の国
2013	2014101035949	一种低阶煤催化解聚增油催化剂	2014/3/20	太原理工大学	CN201410103594.9	黄伟, 梁虎珍, 梁丽彤, 高福星, 郝晓刚, 张忠林	"相手国"
2014	2014101823631	一种采用酸性离子液体预处理提高褐煤热解焦油产率与品质的方法	2014/4/30	安徽工业大学	ZL 201410182363.1	雷智平, 张昊, 朱平, 水恒福	"相手国"
2014	BR 11 2014 022628-8	一种用于宽粒径分布煤的干馏装置及方法	2014/9/12	中科院过程工程研究所		许光文, 韩江则, 武荣成, 张纯, 高士秋	その他の国
2014	2014107581513	一种城市污泥制备高浓度污泥煤浆的方法	2014/12/12	湖南科技大学		戴财胜, 马淞江, 刘学鹏	"相手国"
2014	2015201169233	负压式快速分离层析柱	2015/2/27	中国矿业大学	ZL201520116923.3	宗志敏, 王铁民, 刘静, 张栋栋, 吕璟慧, 魏贤勇	"相手国"
2014	2015201169638	新型超声波清洗机	2015/2/27	中国矿业大学	ZL201520116963.8	宗志敏, 张栋栋, 刘静, 王铁民, 吕璟慧, 魏贤勇	"相手国"
2015	2015101600089	一种热解气化装置和工艺	2015/4/7	太原理工大学		郝晓刚, 王俊丽, 连文豪, 张忠林, 黄伟	"相手国"
2015	2015102045923	一种带有易拆卸层析柱的加压柱层析成套装置	2015/4/27	中国矿业大学	ZL201520261932.1	宗志敏, 周明耀, 桂娟, 王敬贤, 王升康, 李炜图, 刘祥雪, 陈友响, 滕青青, 徐丹丹, 魏贤勇	"相手国"
2015	2015103056200	一种低级烷烃芳构化反应-再生体系构建的工艺	2015/6/3	西北大学	105061127A	闫鹏 马晓迅 张战国 李大鹏 王明峰 程序 张新庄 杨帆 胥月兵 刘建国 霍鹏举 王永娟	"相手国"
2015	2015104014474	一种甲烷二氧化碳重整制合成气炭基催化剂的方法	2015/7/9	西北大学		徐龙, 刘鹏, 孙鸣, 马晓迅	"相手国"



2015	2015104643781	一种从空气中提取富氧和富氮气体的系统与amp;方法	2015/7/31	西北大学	105036084A	张建波 马晓迅	”相手国”
2015	2015107410073	一种煤焦油组分分离装置及分离工艺	2015/11/3	西北大学		孙鸣 马晓迅 吕波, 徐龙	”相手国”

**5. 3. 共同出願  
Joint Applications**

出願年度	出願番号	発明の名称	出願日	出願人	公開番号	発明者	出願国
2015	特願2015-248669	バイオマス処理用触媒、バイオマス処理用触媒の製造方法、バイオマス処理装置、及びバイオマス処理方法	2015/12/21	群馬大学		宝田 恭之、神成 尚克	日本

## 6 受賞等 Awards

### 6.1 受賞 Awards

年度	賞の名称	受賞日	受賞者	特記事項
2013	化学工学会盛岡大会2013奨励賞	2013/8/8	Malinee Kaewpanha	
2013	化学工学会盛岡大会2013奨励賞	2013/8/8	Jenny Rizkiana	
2013	Excellent Paper Award for Oral Presentation, The 1st Asian Conference on Biomass Science, Kochi, Japan	2014/1/14	Narumon Thimthong, Ryota Tanaka, Shinji Kudo, Jun-ichiro Hayashi, and Koyo Norinaga	
2013	陝西高等学校科学技术奖一等奖	2014/2/1	陈斌、李蓉、范代娣、马晓迅等	
2013	日本エネルギー学会 奨励賞	2014/2/26	上村和大	
2013	化学工学会第79年会学生特別賞	2014/3/19	馬宇飛	
2014	The best poster presentation award, The 23rd International Symposium on Chemical Reaction Engineering (ISCRE 23)(Bangkok, Thailand)	2014/9/10	Narumon Thimthong, Ryota Tanaka, Shinji Kudo, Jun-ichiro Hayashi, and Koyo Norinaga	
2014	第四届淮海科学技术奖	2014/11/10	魏贤勇, 赵炜, 曹景沛, 赵小燕, 宗志敏, 赵云鹏, 樊星, 唐仕荣, 路瑶, 闫洪雷	
2014	2014 年度中国石油和化学工业联合会科学技术奖	2014/11/5	魏贤勇, 曹景沛, 赵云鹏, 赵小燕, 赵炜.	
2014	化学工学会新潟大会2014奨励賞	2014/11/22	Wahyu Bambang Widayatno	
2014	27th International Symposium on Chemical Engineering, Special Award	2014/12/7	Malinee Kaewpanha	
2014	The 2nd Asian Conference on Biomass Science(ABCS2015)、Excellent Paper Award	2015/1/13	Wahyu Bambang Widayatno	
2014	日本エネルギー学会 第10回バイオマス科学会議 ポスター賞	2015/1/15	上村和大, 工藤真二, 林潤一郎, 則永行庸	

2015	日本エネルギー学会 論文賞	2015/8/3	Huamei Yang, Srinivas Appari, Shinji Kudo, Jun-ichiro Hayashi, Satoshi Kumagai, and Koyo Norinaga	
2015	化学工学会第47回秋季大会、優秀ポスター発表賞	2015/9/9	Wahyu Bambang Widayatno	
2015	第47回化学工学会秋季大会・反応工学部会ポスターセッション優秀ポスター発表賞	2015/9/15	古谷優樹、楊華美、工藤真二、林潤一郎、則永行庸	
2015	2015年度中国石油与化学工业联合会科技进步奖	2015/10/1	魏贤勇, 曹景沛, 樊星, 赵炜, 宗志敏, 赵云鹏, 赵小燕, 刘滋武, 梁静, 王欲晓	
2015	2015年度中国石油与化学工业联合会科技进步奖	2015/10/1	魏贤勇, 曹景沛, 樊星, 赵炜, 宗志敏, 赵云鹏, 赵小燕, 刘滋武, 梁静, 王欲晓	

## 6.2 新聞報道 Newspaper Reports

年度	賞の名称	受賞日	受賞者	特記事項
なし				

## 6.3 その他 Other

年度	賞の名称	受賞日	受賞者	特記事項
なし				